

**EN - Instructions and warnings for
installation and use**

FLOR

CE

Receiver

FLOXR family

Nice



ENGLISH

Original instructions

WARNINGS

WORKING IN SAFETY!

CAUTION! – For personal safety it is important to observe these instructions.

CAUTION! – Warning - Important safety instructions: keep these instructions in a safe place.

CAUTION! – All product installation, connection, programming and maintenance operations must be performed exclusively by a qualified and skilled technician.

Observe the following warnings:

- Never make any modifications to part of the product other than those specified in this manual. Unauthorised operations can be the source of hazards and malfunctions. The manufacturer declines all liability for damage caused by makeshift modifications to the product.
- Keep this manual in a safe place to enable future product maintenance and programming operations.
- The product packaging material must be disposed of in full observance of current local legislation governing waste disposal.

1 – PRODUCT DESCRIPTION AND INTENDED USE

This receiver is part of the “Flor” series by Nice spa. This series of receivers is intended for use on the Control units featured in automated systems for gates, garage doors and road barriers. **Any other use is to be considered incorrect and forbidden!** The manufacturer shall not be held liable for damage due to improper use of the product other than that specified in this manual.

2 – PRODUCT TECHNICAL SPECIFICATIONS

• For all models

- The receiver handles “Flor” type radio encoding with a variable code (*rolling-code*) and also recognises the C-Code encoding of the Opera series for the basic functions.
- These models have 1 or 2 relays with clean contact output; they can therefore be used with any type of Control unit.

3 – PRODUCT INSTALLATION

• For models with “NICE” connector

These models are connected to the Control system by inserting their connector into the specific one featured on the Control unit. **Important! – Before connecting or removing the receiver, cut off the electricity supply to the Control unit.**

In addition, you should install the aerial provided, connecting it to the purpose-provided terminals on the Control unit.

Fig. 1 illustrates the electrical connections on the connector:

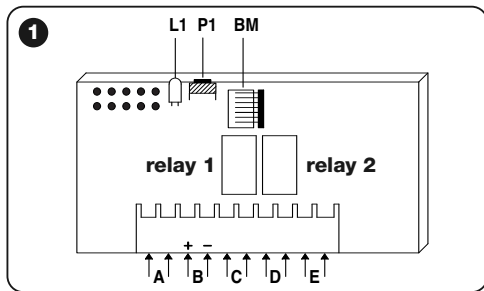

- A = not used
- B = electricity supply
- C = relay 1 output
- D = relay 2 output
- E = aerial

• **For models with universal connection**

These models with a terminal board make universal use possible; they can be wall-mounted using screws (not provided) or using the adhesive on the bottom of the box.

Opening of the box for receivers with universal connection:

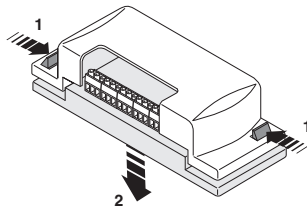

— **Electrical connections** —

Make the connections as follows (fig. 2):

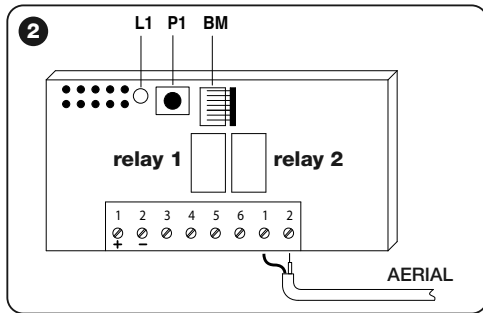

- 1-2 POWER SUPPLY** 12/24 V direct or alternating.
- 3-4 1st RELAY OUTPUT:** clean contact of a normally open relay.
- 5-6 2nd RELAY OUTPUT:** clean contact of a normally open relay (only on receivers with 2 channels).
- 1-2 AERIAL:** aerial signal input.

— Installing an external aerial —

If the aerial provided is in an unfavourable position and the radio signal is weak, we recommend you improve reception by replacing the aerial through the installation of an external one (mod. ABF or ABFKIT). The new aerial should be positioned as high as possible and above any metallic or reinforced concrete structures in the area.

If necessary, use a coaxial cable with an impedance of 50 ohm (for example, the RG58 low-loss cable). **Important!** – *To reduce signal dispersion, use the shortest possible cable (it should not exceed 10 m in length).*

- **Aerial connection (only for models with universal connection):** connect the aerial cable to terminal **1** and **2** (fig. 2): **terminal 1 = sheath; terminal 2 = core.**
- **Aerial connection for models with Nice connector:** connect the aerial cable to the purpose-provided terminals on the control unit.

• For all models:

— Relay selection on channels —

Each receiver is designed to recognise all 4 keys on the transmitter. This is possible thanks to the association of the

output relays with the desired key, through an electric jumper which should be inserted in the purpose-provided connectors: see **Table 1**.

TABLE 1	
Relay 1 Output	Relay 2 Output (where present)
	Key: 1
	Key: 2
	Key: 3
	Key: 4

— How to obtain “NC” type contacts —

The outputs are operated by 2 relays with a “NO” (normally open) type contact. If you want to achieve a “NC” (normally closed) contact, proceed as follows:

- 01.** Disconnect the electrical power supply to the receiver.
- 02.** Remove the board carefully and turn it over: *the side with the welding should be facing you.*
- 03.** On the side with the welding, carry out the following steps (fig. 3):
 - Cut the section of line at point “**X**”.
 - Using a drop of tin, join the spots at points “**Y**”.

Note – *these changes can be made on one relay or on both, depending on your requirements.*

3

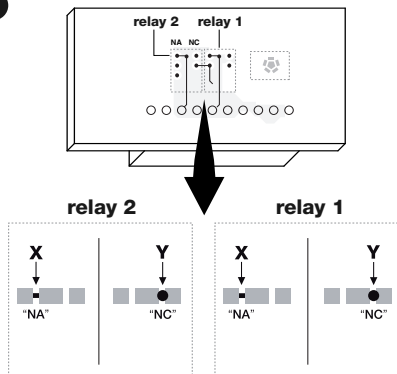

— Selecting the channel on the transmitter —

On the FLOR series of transmitters, the association of the transmitter key with the receiver channel can be modified:

- For **key 1** of the transmitter, proceed as shown in **fig. 4a**: cut the track that associates key 1 with channel 1 and connect one of the other spots on the right with a drop of tin, to obtain the association with channel 2, 3 or 4.
- For **key 2** of the transmitter, proceed as shown in **fig. 4b**.

4 - English

4a

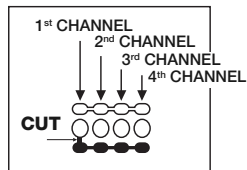
1st KEY

4b

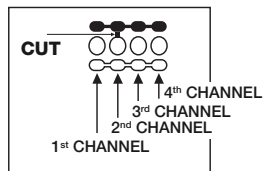
2nd KEY

4 – PROGRAMMING

Warnings

The programming featured in this chapter requires the use of key P1 and of LED L1 on the receiver (fig. 1). To indicate the status of the activity under way, the LED emits a specific number of flashes for a specific amount of time. To find out the meaning of these indications, please consult **Table 2**.

To facilitate programming, you can use the BUPC and OBox programmers.

TABLE 2
SIGNALS EMITTED BY LED L1 ON THE RECEIVER

— SLOW 1/2 second FLASH —

- 1 * = The code received is not among those authorised.
- 2 * = Recognition time over without success.*
- 3 * = Recognition successfully completed (code authorised).
- 4 * = The code is already in the list of those authorised.
- 5 * = The list is empty (no code).
- 6 * = The list is full (there is no room for any more codes).
- 7 * = The deletion of a non-existent code has been requested.
- 8 * = Different codes were received during the recognition phase.
- 9 * = Password entered.

*** Note**

- If the software memory lock is activated, the 2nd flash is longer than the 1st one
- If the software memory lock is deactivated the two flashes are the same.

— FAST 1/4 second FLASH —

• **During initialisation:**

- 1 * = A BM60 memory is present
- 2 * = A BM250 memory is present
- 3 * = A BM1000 memory is present
- 4 * = The memory has codes entered which are not from the Flor version
- 5 * = An error was detected during memory reading

• **During operation:**

- 1 * = The code received is a “copy”; only “original” codes are valid.
- 3 * = The code is not inside the codes window, but it has been resynchronised.
- 4 * = The code is not inside the codes window and resynchronisation is locked.
- 5 * = The code is not inside the codes window and resynchronisation is not possible.

The receiver is fitted standard with the BM250 memory which can store up to 63 codes; when the receiver is powered, it displays the type of memory used with various flashes of LED L1 (fig. 1), see Table 2.

The usable memories are as follows:

- memory **BM60** = 16 storable codes
- memory **BM250** = 63 storable codes
- memory **BM1000** = 255 storable codes

The memory contains all the transmitter codes stored; to obtain maximum safety and avoid the accidental storage of foreign codes, you can lock the code recognition function (see paragraph 6.1 - Locking the memory).

4.1 – Storage of a transmitter

A transmitter (its code) can be stored in the memory of a receiver in two ways:

- rapid mode
- standard mode

4.1.1 – Rapid mode

This is the quickest mode to use, but it is not extremely safe because during the code storage operation, the receiver may acquire a different signal from another transmitter within its operating range and store it by mistake. We recommend you assess this risk before selecting your storage mode.

- 01.** Press and keep key **P1** (fig. 1) on the receiver pressed: LED **L1** is turned on;
- 02.** Press any key on the transmitter and transmit the code until LED **L1** on the receiver is turned off;
- 03.** Then release the key on the transmitter: LED **L1** is turned back on and the receiver is ready for another task;
- 04.** To store the other transmitters, repeat the process from step 02. When storage is complete, release key **P1** on the receiver.

4.1.2 – Standard mode

- 01.** Press and release key **P1** (fig. 1) on the receiver; LED **L1** is turned on for 5 sec.;
- 02.** During these 5 sec. transmit the code until LED **L1** on the receiver is turned off;
- 03.** Then release the key on the transmitter and wait for 1 sec.;

- 04.** Press and keep any key on the transmitter pressed, to send the code, until LED **L1** on the receiver is turned off; the LED will emit three flashes to indicate that the process was successful;
If this does not happen, then repeat the process.
- 05.** To store the other transmitters, repeat the process from step 01.

N.B. – To avoid the storage in the receiver of a signal casually transmitted by a transmitter which has nothing to do with the automated system in question, the BM memory can be locked; please see paragraph 5.4.

4.1.3 – Storage of a transmitter using the procedure 'in the vicinity of the receiver' (with a transmitter already stored)

A NEW transmitter can be stored in the memory of the receiver without intervening directly on the key of this receiver, but simply by operating in its range of reception. To implement this procedure, you need to have an OLD transmitter at hand, which has already been stored and is operational.

Warnings:

- *The procedure must be performed while operating in the range of reception of the receiver (10-20 m from the receiver).*
 - *Repeat the entire process for each transmitter you wish to store.*
- 01.** On the NEW transmitter, keep key... pressed for at least 5 seconds. and then release it.
 - 02.** On the OLD transmitter, press keythree times and then release it.

03. On the NEW transmitter, press the same key as in step 01 once and then release it.

4.2 – Total deletion of the receiver memory

WARNING! – When you do this, the software lock function is also deleted and the "Timer" is automatically set to 3 sec.

01. Press and keep key **P1** (fig. 1) on the receiver pressed: after 3 sec. LED **L1** is turned off;
02. When LED **L1** starts flashing again, on the 3rd flash, release key **P1** and wait approximately 3 sec.;
03. As soon as LED **L1** is turned back on, press key **P1** and release it as soon as the LED is turned off.

Depending on the type of memory fitted on the receiver, the process may take a few seconds. During this phase, LED **L1** flashes quickly, followed by 5 slow flashes to indicate that total deletion was successful and that the memory is empty. If this does not happen, then repeat the process.

4.3 – Deletion of a single transmitter from the receiver memory

01. Press and keep key **P1** (fig. 1) on the receiver pressed for approximately 3 sec.: LED **L1** is turned off, then release the key;
02. Press and keep any key on the transmitter pressed, to send the code, until LED **L1** on the receiver is turned off;
03. Release the key on the transmitter and wait 1 sec.;
04. Press and keep any key on the transmitter pressed, to confirm: LED **L1** emits 1 flash to indicate that the code has been deleted.

If this does not happen, then repeat the process from step 01.

5 – OTHER FUNCTIONS

Usually the output relay function is momentary: i.e. the relays are activated a few seconds after a key is pressed on the transmitter (delay due to the code recognition time) and the activation ends 300 mS after the receipt of the last valid code.

Below is a description of other special functions, available for the output relays.

IMPORTANT! – To activate the special functions, you will need to use a small drop of tin, see fig. 5.

5.1 – STEP-STEP Function

The relay is activated by pressing a key on the transmitter and it remains activated even after the key has been released; the key needs to be pressed again to deactivate the relay.

5.2 – TIMER Function

The relay is activated by pressing a key on the transmitter and it remains activated until the programmed amount of time lapses. The countdown of the programmed time restarts every time the key on the transmitter is pressed again and it can be stopped early by keeping the same key pressed for at least 3 sec.

5.2.1 – Programming the timer

To program the timer, you need to activate the TIMER func-

tion (electric jumper 3, **fig. 5**). If - during programming - you prefer the relays not to be activated, you will need to remove the electric jumper for the channel selection temporarily.

Programming

01. Press and keep key 1 of an operational transmitter pressed;
02. Within 3 sec., also press and keep key **P1** (**fig. 1**) on the receiver pressed and then release the key on the transmitter;
03. Keep key **P1** pressed for the time you wish to program (max 2 h 30') and then release key **P1**.

At this stage, the desired time has been stored and remains valid until a new programming is performed.

Note – During the timer programming phase, the normal operation of the receiver is inhibited.

5.3 – BURGLAR ALARM Function

Activate this function to obtain the combined function of relays 1 and 2. Press key 1 on the transmitter to obtain the "Step-step" function on relay 1 of the receiver (this function is suitable for enabling/disabling a burglar alarm).

Concurrently, relay 2 (where present) performs 1 brief activation when relay 1 switches from OFF to ON and 2 brief activations when relay 1 switches from ON to OFF.

This way, relay 2 can be connected to an optical or acoustic signal which can be used to notify that a burglar alarm has been enabled/disabled.

Note – If this function is activated, relay 2 maintains its normal operation associated with key 2 of the transmitter.

5

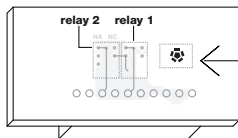
**NO JUMPER**

all channels momentary

**JUMPER 1**

1 step-step....2, 3, 4 momentary

**JUMPER 2**

1, 2 step-step....3, 4 momentary

**JUMPER 3**

1 timer....2, 3, 4 momentary

**JUMPER 4**

1 + 2 burglar alarm....3, 4 momentary

**JUMPER 5**

all channels step-step

5.4 – Locking the memory

There are two ways to do this:

- Locking the memory via the hardware (paragraph 5.4.1)
- Locking the memory via the software (paragraph 5.4.2)

5.4.1 – Activating the memory lock: hardware

This locking mode is very simple to perform but it is not very safe. Indeed, it can easily be cancelled by outsiders.

IMPORTANT! – The memory enabling/disabling operations must be performed with the receiver not powered.

After inserting the desired transmitter codes, proceed as shown in **fig. 6**: cut (X) the track indicated by the arrow.

If you later wish to insert other codes, proceed as shown in **fig. 6**: join (Y) the two spots with a drop of tin.

5.4.2 – Activating and deactivating the memory lock: software

This is a safer way to activate the memory lock. In fact, you

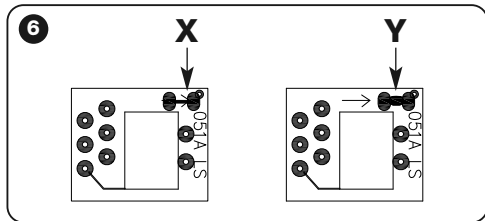

need to have a transmitter that has already been stored in the receiver to deactivate it.

• **Activating the memory lock**

- 01.** Press and immediately release key **P1** (**fig. 1**) on the receiver;
- 02.** Wait for LED **L1** to flash twice, indicating the time is up (approx. 5 sec.) and at the 2nd flash, press key **P1** and then release it when LED **L1** is turned off.

Next, LED **L1** emits two flashes: if the second flash lasts longer than the first, this means that the memory lock has been activated. If the flashes last the same, this means that the memory lock has not been activated. In this case, repeat the process from step 01.

• **Deactivating the memory lock**

To deactivate the memory lock, you need to have a transmitter that has already been stored. Proceed as follows:

- 01.** Press and immediately release key **P1** (**fig. 1**) on the receiver: LED **L1** is turned on for 5 sec.;
- 02.** During these 5 sec. press any key on the transmitter, to transmit the code, until LED **L1** is turned off;
- 03.** Then release the key on the transmitter and wait for 1 sec.;
- 04.** Press and keep any key on the transmitter pressed, to send the code: LED **L1** will emit 4 flashes to indicate that that code is already on the list;
- 05.** During the 4th flash, press key **P1** and release it when LED **L1** is turned off.

Next, LED **L1** will emit 2 flashes for the same amount of time, which means that the memory lock is no longer activated.

If this does not happen, then repeat the process from step 01.

The memory lock can also be activated in a safer and more controlled way: using a "PASSWORD": this method can only be implemented with the use of the BUPC and OBox programmers.

DISPOSING OF THE PRODUCT

This product is an integral part of the automation system, and should therefore be disposed of together with it.

As for the installation operations, even at the end of this product's life span, the dismantling operations must be carried out by qualified experts.

This product is made up of various types of materials: some can be recycled while others need to be disposed of. Find out about the recycling or disposal systems envisaged by your local regulations for this product category.

Important! – parts of the product could contain pollutants or hazardous substances which, if released into the environment, could cause harmful effects to the environment itself as well as to human health.

As indicated by the symbol opposite, throwing away this product as domestic waste is strictly forbidden. So dispose of it as differentiated waste, in accordance with your local regulations, or return the product to the retailer when you purchase a new equivalent product.

Important! – the local applicable regulations may envisage heavy sanctions in the event of illegal disposal of this product.



PRODUCT TECHNICAL SPECIFICATIONS

WARNINGS:

- All technical specifications are referred to a room temperature of 20°C (± 5°C).
- Nice S.p.a. reserves the right to make any changes deemed necessary to the product at any time while maintaining the same functions and intended use.
- The operating distance between transmitters and receivers (range) is heavily influenced by other devices operating in the vicinity at the same frequency (for example headphones, alarm systems, etc.). In such cases, Nice cannot provide any guarantee as regards the effective range of its devices.

- **Decoding:** "FloR"
- **Power supply:** 12-24 V direct or alternating. Limits from 10 to 28 V
- **Power consumption when idle:** 16 mA at 24 VDC
- **Power consumption with 2 relays active:** 80 mA at 24 VDC
- **Reception frequency:** 433.92 MHz
- **Sensitivity:** better than 0.5 μV
- **No. of relays:** 1 or 2 depending on the model
- **Normally open relay contact:** max 0.5 A and 50 V SELV
- **Operating temp.:** from -20° C to +55° C
- **Protection rating:** IP 30
- **Dimensions and weight:** 58 mm x 86 mm x H 22 mm; 55 g

EC DECLARATION OF CONFORMITY

Note – This Declaration of Conformity gathers the contents of all the individual declarations of conformity of each product mentioned herein; it is updated to the date of publication of this manual and was re-adapted for publishing purposes. A copy of the original declaration for each product can be requested from Nice S.p.a. (TV) I.

Number: 201/FLOX

Revision: 2

The undersigned Luigi Paro, as Managing Director, declares on his own responsibility that the product:

Name of manufacturer: NICE s.p.a.

Address: Via Pezza Alta 13, Z.I. Rustignè, 31046 Oderzo (TV) Italy

Type: 433.92MHz receiver for the remote control of automated gates, doors, blinds, awnings, shutters and similar applications

Models: FLOX1, FLOX2, FLOXI, FLOXB2, FLOXI2, FLOXM, FLOXM220

Accessories:

Compliant with the essential requirements provided for in Art. 3 of the following EC directive, for the use for which the products are intended:

- 1999/5/EC DIRECTIVE 1999/5/EC OF THE EUROPEAN PARLIAMENT AND OF THE COUNCIL of 9 March 1999 concerning radio equipment and terminal telecommunications units and the reciprocal acknowledgment of their compliance

In accordance with the following harmonized standards health protection: EN 50371:2002; electrical safety: EN 60950-1:2006;

electromagnetic compatibility: EN 301 489-1V1.8.1:2008; EN 301 489-3V1.4.1:2002; radio spectrum: EN 300 220-2 V2.1.2:2007

Oderzo, 20th March 2009

Luigi Paro (Managing Director)





Nice

Nice SpA
Oderzo TV Italia
info@niceforyou.com

www.niceforyou.com

IS0063A00MM_13-07-2011