

Nice

CE

SHEL60KIT
SHEL75KIT

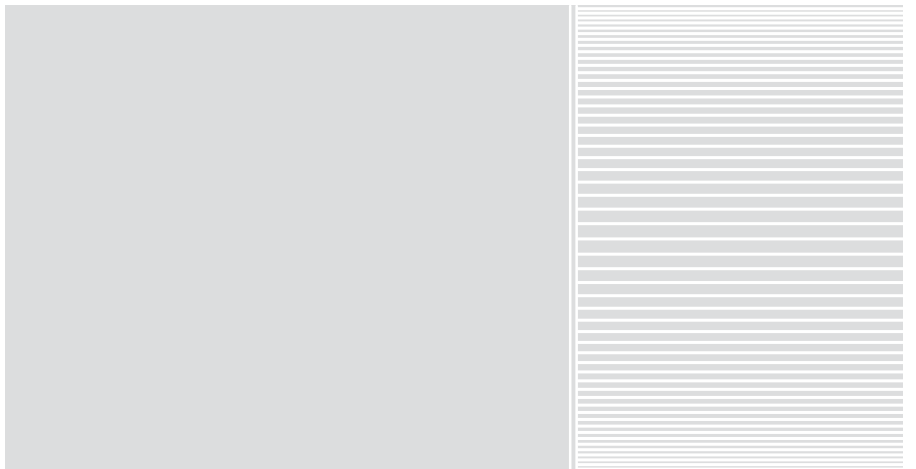

Garage door opener

EN - Instructions and warnings for installation and use

Nice

GENERAL SAFETY WARNINGS AND PRECAUTIONS**STEP 1**

- Working in safety! 2
- Installation warnings. 2

KNOWLEDGE OF THE PRODUCT AND PREPARATION FOR INSTALLATION**STEP 2**

- 2.1** - Product description and intended use 2
- 2.2** - Components used to set up a complete system 2

STEP 3

- Preliminary checks for installation 3
- 3.1** - Checking suitability of the environment and door to be automated. . . 3
- 3.2** - Checking product application limits 3

STEP 4

- 4.1** - Preliminary set-up work 3
- **4.1.1** - *Typical reference system* 3
- **4.1.2** - *Establishing positions of components* 3
- **4.1.3** - *Establishing the device connection layout* 3
- **4.1.4** - *Checking the tools required for the work* 3
- **4.1.5** - *Completing the set-up work* 3
- 4.2** - Laying the electric cables 3

INSTALLATION: COMPONENT ASSEMBLY AND CONNECTION**STEP 5**

- 5.1** - Installing the automation components 4
- 5.2** - Fixing the automation to the wall, ceiling, and door. 4

STEP 6

- System device installation and connection 5

POWER SUPPLY CONNECTION

- STEP 7** 5

INITIAL START-UP AND ELECTRICAL CONNECTIONS CHECK

- STEP 8** 5

PROGRAMMING THE AUTOMATION**STEP 9**

- 9.1** - Memorisation of transmitter mod. FLO4R-S 6
- 9.2** - Memorising the door "Opening" and "Closing" travel limit positions . . . 6

DJUSTMENTS AND OTHER OPTIONAL FUNCTIONS

- 10** - Automation operation adjustment 6
- 11** - Deleting data from the Control unit memory 7

- WHAT TO DO IF... (troubleshooting guide)** 8

TASKS RESERVED FOR QUALIFIED TECHNICIANS

- Connecting the automation to the electrical mains 8
- Automation testing and commissioning 8
- Product disposal 9
- CE declaration of conformity 9

- TECHNICAL SPECIFICATIONS OF COMPONENTS** 10

- OPERATION MANUAL** I

- IMAGES** VIII - XIV

GENERAL SAFETY WARNINGS AND PRECAUTIONS

STEP 1

WORKING IN SAFETY!

⚠ Please note - These instructions must be followed to guarantee personal safety.

⚠ Please note - Important safety instructions. Keep for future reference.

The design and manufacture of the devices making up the product and the information in this manual fully comply with current standards governing safety. However, incorrect installation or programming may cause serious physical injury to those working on or using the system. For this reason, during installation, always strictly observe all instructions in this manual.

If in any doubt regarding installation, do not proceed and contact the Moovo Technical Assistance Nice for clarifications.

If this is the first time you are setting up an automation for garage doors (sectional or up-and-over), we recommend that you read this entire manual with care. This is preferable before any work, without any hurry to start practical tasks.

Also keep product devices on hand while consulting the manual to enable testing and checking (excluding any programming phases) with the information provided in the manual.

While reading this manual, take care to observe all instructions marked with the following symbol:



These symbols indicate subjects that may be the source of potential hazards and therefore the prescribed operations must be performed exclusively by qualified and skilled personnel, in observance of these instructions current safety standards.

⚠ INSTALLATION WARNINGS

According to the most recent legislation, the installation of a garage door must be in full observance of the standards envisaged by European Directive 98/37/EC (Machinery Directive) and in particular standards EN 12445, EN 12453 EN 12635 and EN 13241-1, which enable declaration of presumed conformity of the automation.

In consideration of the above,

The final connection of the automation to the electrical mains, system testing, commissioning and periodic maintenance must be performed by skilled and qualified personnel, in observance of the instructions in the section "Tasks reserved for qualified technicians". These personnel are also responsible for the tests required according to the risks present, and for ensuring observance of all legal provisions, standards and regulations, and in particular all requirements of the standard EN 12445, which establishes the test methods for checking automations for garage doors.

However, all preliminary set-up, installation and programming operations may be performed by personnel with standard skills, provided that all instructions and the relative sequences in this manual are strictly observed, with special reference to the warnings in STEP 1.

Before starting installation, perform the following checks and assessments:

– ensure that each device used to set up the automation is suited to the intended system. For this purpose, pay special attention to the data provided in the paragraph "**Technical specifications**". Do not proceed with installation if any one of these devices does not correspond to specifications.

– ensure that the devices in the kit are sufficient to guarantee system safety and functionality.

– an assessment of the associated risks must be made, including a list of the essential safety requirements as envisaged in *Appendix I of the Machinery Directive*, specifying the relative solutions adopted. Note that the risk assessment is one of the documents included in the automation Technical documentation. This must be compiled by a professional installer.

Considering the risk situations that may arise during installation phases and use of the product, the automation must be installed in observance of the following warnings:

– never make any modifications to part of the automation other than those specified in this manual. Operations of this type will lead to malfunctions. The manufacturer declines all liability for damage caused by makeshift modifications to the product.

– ensure that parts of the automation cannot come into contact with water or other liquids. During installation ensure that no liquids penetrate the gearmotors

or other devices present.

– should this occur, disconnect the power supply immediately and contact a Nice service centre. Use of the automation in these conditions constitutes a hazard.

– never place automation components near to sources of heat and never expose to naked flames. This may damage system components and cause malfunctions, fire or hazardous situations.

– all operations requiring opening of the protection housings of various automation components must be performed with the control unit disconnected from the power supply. If the disconnect device is not in a visible location, affix a notice stating: "WARNING! MAINTENANCE IN PROGRESS".

– the wall-mounted pushbutton panel must be positioned in sight of the shutter, but far from moving parts and at a height of at least 1.5 m from the ground, not accessible by the public.

– ensure that there are no risks of crushing during the *Closing* manoeuvre; install additional safety devices where necessary.

– if the door to be automated is fitted with a pedestrian door, the system must be set up with a control system to prevent motor operation when the pedestrian door is open.

– on the system power mains install a device for disconnection, to guarantee a gap between contacts and complete disconnection in the conditions of over-voltage category III.

– if the power cable is damaged, it must be replaced by Nice, by the assigned technical service centre or in any event by a person with similar qualifications to prevent all risks.

– this product is not designed to be used by persons (including children) whose physical, sensorial or mental capacities are reduced, or with lack of experience or skill, unless suitable instructions regarding use of the product have been provided by a person responsible for safety.

– the product may not be considered an efficient system of protection against intrusion. If an efficient protection system is required, the automation must be integrated with other devices.

– connect the control unit to an electric power line equipped with an earthing system.

– the product may only be used after completing the automation "commissioning" procedure as specified in paragraph "**Automation testing and commissioning**" provided in the section "Tasks reserved for qualified technicians".

– The automation component packaging material must be disposed of in full observance of current local legislation governing waste disposal.

KNOWLEDGE OF THE PRODUCT AND PREPARATION FOR INSTALLATION

STEP 2

2.1 – PRODUCT DESCRIPTION AND INTENDED USE

In general, the series of devices that make up this product serve to automate a garage door for residential applications (**fig. 1**). This type may be "sectional" or "up-and-over"; up-and-over doors may be projecting (during opening the door protrudes outwards) or non-projecting with springs or counterweights.

In particular, this kit is designed for the automation exclusively of sectional garage doors. Therefore, to automate an up-and-over door, the special oscillating arm must be fitted (mod. SPA5, not supplied in pack).

Any other use than as specified herein or in environmental conditions other than as stated in STEP 3 is to be considered improper and is strictly prohibited!

This product comprises an electromechanical gearmotor with a 24 V dc motor, a guide, chain and a drive carriage. The gearmotor is also equipped with a control unit.

The control unit comprises an electronic board, a courtesy/indicator light and a built-in radio receiver, plus an aerial, which receives the commands sent by a transmitter.

The control unit can control different types of manoeuvres, each programmable and usable according to specific requirements.

Special functions are also available to enable personalisation of automation operation.

The automation is designed for use with various accessories which enhance functionality and guarantee optimal safety. More specifically, the control unit can memorise up to 150 keys of transmitters mod. FLO4R-S and up to 4 pairs of photocells, mod. MOF/MOFO.

The product is mains-powered, and, in the event of a power failure enables manual movement of the door, by release of the drive carriage using a special cord.

2.2 – COMPONENTS USED TO SET UP A COMPLETE SYSTEM

Fig. 2 illustrates all components used to set up a complete system, such as that shown in **fig. 8**.

WARNING!
Some components shown in fig. 2 are optional and may not be supplied in the pack.

List of components:

- [a] - electromechanical gearmotor
- [b] - integral guide
- [c] - gearmotor ceiling mounting brackets
- [d] - gearmotor wall-mounting brackets
- [e] - mechanical stop for carriage travel limit
- [f] - chain gear
- [g] - drive chain
- [h] - door drive rod (for sectional doors only)
- [i] - drive carriage
- [j] - automation release knob and cord
- [m] - bracket for connection of drive rod to door
- [n] - oscillating arm and relative drive rod (mod. SPA5, for up-and-over doors only)
- [o] - pair of photocells (wall-mounted) mod. MOF/MOFO
- [p] - transmitter (portable) mod. FLO4R-S
- [q] - radio control keypad mod. MOTXR (wall-mounted)
- [r] - Metal hardware (screws, washers, etc.)*

(* Note – The screws required for wall-fixture of components are not included in the pack, as their type depends on the material and thickness of the door in which they are inserted.

STEP 3

PRELIMINARY INSTALLATION WORK

Before proceeding with installation, check the condition of the product components, suitability of the selected model and conditions of the intended installation environment.

IMPORTANT – The gearmotor cannot be used to power a door that is not fully efficient and safe. Neither can it solve defects caused by poor installation or insufficient maintenance of the door itself.

3.1 – CHECKING SUITABILITY OF THE ENVIRONMENT AND THE DOOR TO BE AUTOMATED

- In the case of automating a projecting up-and-over door, ensure that movement does not obstruct public roads or pavements.
- Ensure that the mechanical structure of the door is suitable for automation and complies with local standards.
- Check stability of the mechanical structure of the door, ensuring that there is no risk of guides coming out of their seats.
- Move the door manually to *open* and *close*, checking that movement has the same degree of friction throughout all points of travel (*no increase in friction must occur*).
- Ensure that the door is correctly balanced: in other words, if left stationary (manually) it must not move from any position.
- Ensure that the space around the automation enables safe and easy manual release.
- Ensure that the selected surfaces for installation of the various devices are solid and guarantee a stable fixture.
- Ensure that all devices to be installed are in a sheltered location and protected against the risk of accidental impact.
- Ensure that the selected surfaces for fixing the photocells are flat and enable correct alignment between photocells.

3.2 – CHECKING PRODUCT APPLICATION LIMITS

To ascertain suitability of the product with respect to the specific features of the door and area to be automated, the following checks should be performed as well as a check for compliance of the technical data in this paragraph and the chapter “**Product technical specifications**”.

- Ensure that the dimensions and weight of the door are within the following limits of use.

Note – The shape of the door and weather conditions, such as the presence of strong winds, can reduce the above maximum values. In these cases it is important to measure the force required to move the door in the worst conditions and compare these with the technical specifications of the gearmotor.

	SHEL60KIT	SHEL75KIT
Sectional doors	350 x 240 cm	400 x 240 cm
Projecting up-and-over doors	350 x 280 cm	400 x 280 cm
Non-projecting up-and-over doors	350 x 220 cm	400 x 220 cm

- Ensure that the area for mounting the gearmotor and guide is compatible with the overall dimensions of the automation to be installed. Then ensure that the minimum and maximum clearances can be observed as shown in fig. 3, 4 and 5.

Caution! – If the results of these checks do not conform to specifications, this model cannot be used to automate your door.

STEP 4

4.1 – PRELIMINARY SET-UP WORK

4.1.1 – Typical reference system

Fig. 6, 7, 8 provide an example of an automation system set up with the components compatible with this product. These parts are positioned according to a typical standard layout. The following components are used:

- a - Electromechanical gearmotor
- b - Carriage sliding guide
- c - drive carriage
- d - mechanical stop for carriage travel limit
- e - carriage manual release knob
- f - bracket for connection of carriage to door
- g - pair of photocells (wall-mounted) mod. MOF/MOFO
- h - radio control keypad (wall-mounted) mod. MOTXR
- i - portable transmitter mod. FLO4R-S
- l - Pushbutton

4.1.2 – Establishing positions of components

With reference to figs. 6, 7, 8, locate the approximate position for installation of each component envisaged in the system.

4.1.3 – Establishing the device connection layout

With reference to fig. 10 and STEP 6 establish the connection layout for all system devices.

4.1.4 – Checking the tools required for the work

Before starting installation, ensure that there is all equipment and materials required for the work concerned (see example in fig. 9); also ensure that all items are in good condition and comply with local safety standards.

4.1.5 – Preliminary set-up work

Dig the routes for the ducting used for electrical cables, or alternatively external ducting can be laid, after which the pipelines can be embedded in concrete and other preparation work for the installation can be completed to finalise the site ready for subsequent installation operations.

CAUTION! – Position the ends of the ducting used for electrical cables in the vicinity of the points envisaged for fixture of the various components.

Notes:

- The ducting serves to protect electrical cables and prevent accidental damage in the event of impact.
- The “fixed” control devices must be visible from the door but positioned far from moving parts and at a minimum height of 150 mm.

4.2 – LAYING THE ELECTRIC CABLES

With the exception of the system connection to the mains by means of the plug and socket, the rest of the system runs on very low voltage (approx. 24 V) and therefore laying of electric cables may be performed by personnel with standard skills, provided that all instructions in this manual are strictly observed. For laying electric cables, refer to fig. 10 specifying the type of cable to be used for each connection.

WARNINGS:

– While laying the electrical cables, do NOT make any electrical connections.

– Arrange for a qualified electrician to install a Shuko 16 A socket, suitably protected, for insertion of the gearmotor power plug. The socket must be positioned so that after connection of the power cable plug, the cable does not hang in the vicinity of mobile parts or hazardous areas.

Technical specifications of electric cables (note 1)

	Devices	Terminals	Function	Cable type	Maximum admissible length
A	Safety photocells	3 - 5	PHOTO input	TX Cable 2 x 0,25 mm ²	20 m (note 2)
				RX Cable 3 x 0,25 mm ²	20 m (note 2)
B	Control pushbutton	3 - 4	Input STEP-STEP	Cable 2 x 0,25 mm ²	20 m (note 2)
C	Safety pushbutton – sensitive edges – etc.	1 - 2	STOP Input	Cable 2 x 0,25 mm ²	20 m (note 2)

Note 1 – The cables required for the set-up of the system (not included in the pack) may vary according to the quantity and type of devices envisaged for the installation.

Note 2 – The connections to terminals 1-2 (Stop), 4-5 (Step-step) and 3-5 (Photo) can be made using a single cable with several internal wires.

CAUTION! – The cables used must be suited to the installation environment; for example a cable type H03VV-F for indoor environments is recommended.

INSTALLATION: COMPONENT ASSEMBLY AND CONNECTIONS

STEP 5

5.1 – INSTALLING THE AUTOMATION COMPONENTS

WARNINGS

• **Incorrect installation may cause serious physical injury to those working on or using the system.**

• **Before starting automation assembly, make the preliminary checks as described in STEP 3.**

After laying the electric cables, proceed with assembly of the mechanical parts of the guides and gearmotor, in the sequence specified below.

01. Insert the guide in the seat on the gearmotor (fig. 11).
02. Insert the travel limit mechanical stop (a) in the guide and move it close to the gearmotor; then position plate (b) onto the stop and secure the assembly by means of a screw (fig. 12). **Note – The screw must NOT be tightened excessively** as the limit stop must later be moved to its final position.
03. Use two screws to secure the ends of the chain into the groove on the carriage plate (fig. 13).
04. Join the two carriage plates; insert the screw in the support of the drive pulley; position the drive pulley in the chain and mount the assembly onto the drive bracket with the pin supplied (fig. 14).
05. Insert the chain and carriage inside the guide, taking care to observe the following:
 - Fig. 15-a)** position the side of the carriage with the chain fixed with the screws on the same side as the control unit cover;
 - Fig. 15-b)** position the carriage to approx. mid-way on the guide.
06. Pass the chain around the pinion of the gearmotor and close the assembly with the protection cover (fig. 16).
07. Insert the bracket on the end of the guide and secure the two elements by means of a nut and washer (fig. 17).
08. Tension the chain by tightening the nut on the screw of the drive bracket (fig. 18). **CAUTION – if the chain is tensioned excessively, this may cause excessive stress and damage the gearmotor; if under-tensioned this may cause unpleasant noise.**

09. FOR UP-AND-OVER DOORS ONLY

If the door to be automated is “up-and-over” (projecting or non-projecting - fig. 1), the **oscillating arm mod. SPA5 must be fitted (fig. 19)**. Then proceed with assembly of the various arm components. **IMPORTANT – Take care to move the arm as close as possible to the handle of the door.**

For assembly of the drive rod, refer to point 10.

Note – for assembly of the accessory, follow the instructions supplied in the pack.

10. **CAUTION!** – If the door is up-and-over, use the drive rod supplied with the oscillating arm for this operation.

Before fitting the drive rod, cut this to a length that ensures observance of recommended distance **E** shown in fig. 3. Then use screws and nuts to

secure one end of the drive rod to the bracket (the one to be fixed to the door or oscillating arm) and the other end to the carriage (fig. 20).

11. Fix one end of the manual release cord to the carriage and the other end to the knob (fig. 21). **Note** – Ensure that the manual release knob is positioned at a maximum height of 180 cm from the ground.

IMPORTANT! – Perform the operations below the door CLOSED

12. • **If the door is SECTIONAL:** establish the length of distance **B** considering the constraints of values **A** and **E** (fig. 3).
 - **If the door is UP-AND-OVER:** establish the length of distance **B** considering the constraints of value **F** (fig. 4).

Note – If values **A**, **E** or **F** allow, the automation can also be fixed directly onto the ceiling (minimum 4 mm).
13. Fold the two ceiling mounting brackets to an “L” and mount in the vicinity of the gearmotor, by means of screws and nuts (fig. 22).

Note – choose the most suitable hole on the brackets to observe distance **B** selected in point 12.

5.2 – FIXING THE AUTOMATION TO THE WALL, CEILING, AND DOOR

After assembly of the guide and gearmotor, fix the automation to the wall, ceiling and door as follows.

01. Using a suitable means of support (ladder, poles or similar) lift the gearmotor from the ground at a position at the required height so that the guide brackets are placed against the ceiling and wall above the door (fig. 23). **IMPORTANT – (fig. 23-a) align the guide and gearmotor with the vertical axis of the door and perpendicular to the latter (90° angle).** **Note** – In the case of up-and-over doors, the guide must be aligned with the oscillating arm.

Also ensure observance of the values **A**, **B**, **E** in fig. 3 and values **B**, **F** in fig. 4.
02. Check the position of the guide, which must be perfectly horizontal, and mark the 4 bracket fixture points, after which drill the relative holes and insert the plugs (fig. 24).
03. Fix the automation to the ceiling and wall using screws and plugs suited to the support material (fig. 26).

Notes:

 - Depending on the type of wall, the bracket at the end of the guide can be fixed by means of the rivets or screws and plugs.
 - Take care when choosing the method of bracket fixture to the ceiling, taking into account the following:
 - the bracket at the end of the guide must withstand the force required to open and close the door;
 - the ceiling mounted brackets must withstand the weight of the gearmotor.

In both cases possible wear and deformation over time must be taken into account.
04. Use a saw to cut off the excess section of the ceiling-mounted brackets (fig. 26).
05. (With the door closed) Pull the release knob and slide the carriage until the anchoring bracket is positioned on the upper edge of the sectional door, or until it reaches the connection of the oscillating arm (up-and-over door). Then align the drive rod along the trajectory of the guide and fix the bracket to the door using rivets or screws suited to the door material (fig. 27).

06. Slightly loosen the travel limit mechanical stop screw and manually open the door until it reaches the maximum *Opening* position (fig. 28).
07. Move the travel limit mechanical stop up against the carriage. Then tighten the travel limit mechanical stop screw fully down (fig. 29).
Note – During normal operation the carriage stops a few centimetres before the mechanical stop.
08. To re-block the door, close it manually until it clicks firmly into place.

STEP 6

After installing all devices in the system – each in the position specified in STEP 4 – connect each device to the control unit as follows.

CAUTION! – *Incorrect connections can cause faults or hazards; therefore ensure that the specified connections are strictly observed.*

01. Use a screwdriver to loosen the screw on the control unit cover and extract the cover (fig. 30), to access the terminals for electrical connections of the control unit.
02. Use the same screwdriver to open the slots required for routing the electric cables (fig. 31) from the various devices in the system.
03. Then connect the electric wires of the system devices to the control unit using the terminal board with five terminals (fig. 32).

CAUTION – The section of electric cable connecting terminals 3 and 5 must only be removed if photocell installation is envisaged.

For correct connections, proceed as follows:

• To connect a pair of photocells with safety function

One or more pairs of photocells with a safety function must be installed on the system. If several pairs of photocells are installed, these must be connected *in series*, and the chain must be connected to terminals 3 and 5 on the control unit. The connect the power supply to terminals 2 and 3 (see example in fig. 33 and fig. 34).

During the Closing manoeuvre, activation of these photocells causes shutdown of the manoeuvre and immediate inversion of movement.

• To connect a NO type pushbutton used for manoeuvre control

An “NO” type pushbutton can be installed on the system, i.e. “normally open” to control manoeuvres in “step-step” mode (for details on this mode, see STEP 9). Connect this pushbutton to terminals 3 and 4 on the control unit.

Note – If several pushbuttons are installed to control manoeuvres, connect these in parallel as shown in the example in fig. 35 and fig. 36.

• To connect safety devices other than photocells

As well as photocells, the system can also be equipped with other safety devices with different types of contact. These are:

- devices with “normally open” contact (“NO”);
- devices with “normally closed” contact (“NC”);
- devices with constant resistance 8,2 K Ω .

These devices can be connected to terminals 1 and 2 on the control unit; also more than one device can be connected to the same terminals as described below:

A) – to connect a series of “NO” type devices, use a “parallel” connection layout as shown the example in fig. 37.

B) – to connect a series of “NC” devices, use a connection layout “in series” as shown in the example in fig. 38.

C) – to connect a series of devices with constant resistance 8,2 K Ω , use a “parallel” connection layout, positioning the resistance (8,2K Ω) on the last device, as shown in the example in fig. 39.

D) – to connect a series of devices with different contact types (“NO”, “NC” and constant resistance 8,2 K Ω), use a connection layout in series and in parallel as shown in the example in fig. 40.

Note – Only the safety devices with an output with constant resistance 8,2 K Ω guarantee safety category 3 against faults according to the standard EN 954-1.

Activation of these safety devices stops the manoeuvre in progress and a brief inversion of movement.

• Powering devices other than those specified in this chapter

As well as those mentioned, the system can also be equipped with other safety devices such as a universal relay receiver. These devices must be connected to terminals 2 and 3 on the control unit. **Caution!** – There is a 24 Vdc power voltage on terminals 2 and 3 with delivery of a current of 100 mA. The total absorbed current of the various devices connected to these terminals must not exceed this value.

WARNING – On completion of connections, secure all cables using special clamps and refit the cover on the control unit.

POWER SUPPLY CONNECTION

STEP 7

WARNINGS!

– The PVC power cable supplied is suitable for indoor installations.

The final connection of the automation to the electrical mains, must be performed by a qualified electrician, in compliance with local standards and the instructions in the section “Tasks reserved for qualified technicians”.

To perform the automation operation and programming tests, insert the **power plug of the control unit** (supplied) in a mains socket (fig. 41). If the socket is far from the automation, use a suitable extension lead.

INITIAL START-UP AND ELECTRICAL CONNECTION CHECK

STEP 8

CAUTION! The following operations described in this manual will be performed on live electrical circuits and therefore manoeuvres may be hazardous! Therefore proceed with care.

After powering up the control unit (fig. 41) perform the following operations, checking conformity of results:

- Immediately after start-up, the red led (fig. 42) flashes quickly for a few seconds, after which the red and green leds light up alternately; then the green led turns off and the red led continues flashing at regular intervals every second (= control unit operating status OK).

CAUTION! - If the red led does not flash as described above, disconnect the Control unit from the power supply and carefully check all connections (refer also to the paragraph “What to do if...”).

- If the system is equipped with photocells, check the RX element to ensure that the led is OFF (= operation OK) or ON (= obstacle present). If the Led is flashing, this means that the signal is poor and subject to incorrect photocell alignment.

- If the system is equipped with a radio control keypad, check operation with reference to the relative instruction manual.

STEP 9

A WARNINGS for programming:

- Always read the procedure **first and then perform** the operations *in the correct sequence*, without leaving more than 10 seconds between releasing one key and pressing the next.
- In this manual the transmitter keys are identified by means of numbers. To check the correspondence of **numbers** and the transmitter **keys** see **fig. 43**.

9.1 – MEMORISATION OF TRANSMITTER MOD. FLO4R-S

To enable control of the automation with the transmitter, the keys must be memorised in the control unit memory. Memorisation enables the association of each key with the required command, selecting from the following:

1 = Step-Step: Corresponds to the sequence ... **Open - Stop - Close - Stop ...** The first command activates Opening; the next, with the leaf moving, activates Stop; the third activates Closure; the fourth with the door moving activates Stop and so on...

2 = Step-Open: Corresponds to the sequence ... **Open - Stop - Close - Open ...** The first command activates Opening; the next, with the leaf moving, activates Stop; the third activates Closure; the fourth with the door moving activates Open and so on...

3 = Partial open: corresponds to a brief opening of the door. This command is only enabled if the door is completely closed.

4 = Courtesy light: ... On - Off - On ...

A single procedure memorises **a single key** of the transmitter; this can be memorised both on the present control unit and on control units of other automations. The control unit memory can memorise up to 100 keys. For each key to be memorised, repeat the following procedure.

01. Select which transmitter **key** is to be memorised (for example: *Key T3*).
02. Decide on the **command** (from those listed below) to be associated with the selected key (for example: *Command "2"*).
03. Press "**P1**" (on the Control unit) the same number of times as the selected command number (in the example "**2**", i.e. twice) and check that the green led emits the same number of quick flashes (repeated at regular intervals).
04. (within 10 seconds) Press and hold the transmitter key to be memorised for at least 2 seconds (in the example, key T3).

If the memorisation procedure is successful, the green led emits 3 long flashes (= memorisation OK). **Note** – Before the 10 second interval elapses, the key of a NEW transmitter with the same command can be memorised (useful, for example, when several transmitters need to be memorised on the same control unit).

Otherwise wait until the green led turns off (= procedure completed) and for the red led to resume flashing at regular intervals.

9.2 – MEMORISING THE DOOR "OPENING" AND "CLOSING" TRAVEL LIMIT POSITIONS

The "Closing" limit position (**B - fig. 44**) corresponds to the maximum door closing position and the "Opening" limit position (**A - fig. 44**) to maximum opening.

In this installation phase, the control unit must memorise the maximum door "Closing" and "Opening" positions and the configuration of the STOP input, using the following procedure:

CAUTION! – The following operations must be performed using exclusively key P1 on the gearmotor control unit.

01. Ensure that the drive carriage is engaged.
02. Press and hold "**P1**" on the Control unit (for approx. 5 seconds) until the red light illuminates, then release.
03. At this point the control unit independently starts 3 consecutive manoeuvres (Closing – Opening – Closing) to automatically memorise the two travel limit positions. **Note** – During the 3 manoeuvres, the courtesy light flashes.

Caution! – During the 3 manoeuvres, if a safety devices is activated or P1 is pressed, the control unit interrupts and automatically cancels the entire procedure. In this case the entire procedure needs to be repeated.

04. Lastly, use the transmitter key **T1** activate 4 or 5 complete Opening and Closing manoeuvres (these manoeuvres are required for the control unit to memorise the **force** values required to move the door at all points of travel).

During memorisation of the force values, the courtesy light will flash.

Caution! – These manoeuvres must not be interrupted; should this occur, the entire procedure must be repeated.

CAUTION! – During the position search process, if the chain on the pin-

ion pulley of the motor emits a rhythmic noise, indicating that tensioning is insufficient. In this case, interrupt the procedure by pressing "P1" on the control unit: then tension the chain by tightening nut and repeat the procedure from the beginning.

This procedure can be repeated at any time: for example after a mechanical travel stop has been moved on the guide.

ADJUSTMENTS AND OTHER OPTIONAL FUNCTIONS

The control unit has a number of optional functions to enable the user to add specific functionalities to the automation, thus personalising the product according to special needs.

10 – AUTOMATION OPERATION ADJUSTMENT

To personalise operation of the automation, a number of functions can be enabled or disabled, also with the option for modifications to settings as required. The functions are:

- **AUTOMATIC CLOSURE.** When this function is enabled, at the end of the Opening manoeuvre command by the user, the control unit automatically closes the door again after a set time interval.
- **MOVEMENT SPEED.** This function enables entry of the required speed of the automation implemented to move the door.
- **SENSITIVITY TO OBSTACLES.** During a manoeuvre, if an obstacle accidentally stops door movement (a gust of wind, a vehicle, person etc.) this function promptly detects the increase in motor stress to contract the obstacle and activates immediate and brief inversion of movement.
- **PRESSURE DISCHARGE.** At the end of the Closing manoeuvre, after the door has closed completely, the motor continues to "push" the door for a brief interval, to ensure perfect closure. Immediately afterwards, this function activates a very brief inversion of movement, to reduce excessive pressure exerted by the motor on the door.

The values of these functions can be set according to personal requirements using the following procedure with a transmitter that has at least one key already memorised on the control unit.

Note – During this procedure, each time a key is pressed the courtesy light illuminates briefly.

01. Press and hold the keys "**T1**" and "**T2**" simultaneously on the transmitter for at least **5 seconds**, after which release. The two leds (green and red) on the Control unit flash to indicate entry to function programming mode (the leds continue to flash throughout the procedure).
02. Press the "**P1**" key on the Control unit **once** (the red and green leds will start flashing).
03. Then select one of the four functions available and on the transmitter press the key associated with the function for at least **1 second** (the green led will flash a number of times equal to the chosen function):
 - **Automatic closure** = (press key "**T1**")
 - **Movement speed** = (press key "**T2**")
 - **Sensitivity to obstacles** = (press key "**T3**")
 - **Pressure discharge** = (press key "**T4**")
04. Lastly, refer to **Table 4**, select the required value in correspondence with the selected function and on the transmitter press the key associated with the selected value for at least **1 second** (the red led will flash a number of times equal to the chosen value).
05. Press the "**P1**" key on the Control unit **once** to terminate the procedure.

Notes to Table 4:

– The Table states the values available for each of the 4 special functions and the corresponding key to be pressed on the transmitter for selection of the specific value.

– The factory settings are highlighted in grey.

TABLE 4

AUTOMATIC CLOSURE

No closure → (press key "T1")
Closure after 15 seconds → (press key "T2")
Closure after 30 seconds → (press key "T3")
Closure after 60 seconds → (press key "T4")

MOVEMENT SPEED

Low Opening / Low closing → (press key "T1")
Low Opening / Fast closing → (press key "T2")
Fast Opening / Low closing → (press key "T3")
Fast Opening / Fast closing → (press key "T4")

SENSITIVITY TO OBSTACLES

High → (press key "T1")
Medium high → (press key "T2")
Medium low → (press key "T3")
Low → (press key "T4")

PRESSURE DISCHARGE

No discharge → (press key "T1")
Minimum → (press key "T2")
Medium → (press key "T3")
Maximum → (press key "T4")

TABLE 5

- Memory of Optional Function values (= 1 press)
- Memory of "Closing" and "Opening" limit positions (= 2 presses)
- Memory of Transmitters (= 3 presses)
- TOTAL memory (= 4 presses) *Note – deletes the first three memories in one process*

11 – DELETING DATA FROM THE CONTROL UNIT MEMORY

Data in the control unit memory can be deleted partially or totally as required. To do this, the following procedures can be used, as required:

- Deletion of a command on a transmitter already memorised
- Deletion of other data memorised on the control unit

Deleting a command on a transmitter already memorised

The following procedure enables deletion of a single command assigned to a transmitter key from the control unit **memory**.

Note – During the procedure, the red and green leds remain permanently lit.

01. Press and hold the key "P1" on the Control unit for at least **10 seconds**: the **green** Led illuminates first, then the **red** led illuminates after 5 seconds and then both, to indicate that the Control unit has entered memory deletion mode (**WARNING! do not release the key P1!**).
02. Without releasing key P1 press the transmitter key to be deleted: if the control unit recognises this operation, the **green** led emits a short flash, after which the **P1** key and transmitter key can be released.

Deleting other data memorised on the control unit

The following procedure enables deletion of various types of memorised data from the control unit **memory**, as specified in **Table 5**.

Note – During the procedure, the red and green leds remain permanently lit.

01. Press and hold the key "P1" on the Control unit for at least **10 seconds**: the **green** Led illuminates first, then the **red** led illuminates after 5 seconds and then both, to indicate that the Control unit has entered memory deletion mode. Then release the key.
02. With reference to **Table 5**, select the data to be deleted and press **P1** the same number of times as the number of presses specified in brackets (*the green led emits one flash each time the P1 key is pressed*).
03. 5 seconds after the key "P1" is pressed for the last time, if deletion is successful, both leds (red and green) flash quickly (= *memory deleted!*).

Note – Before deletion, there is a margin time of 5 seconds, in which the user has the option to change decision and exit the procedure without deleting data by pressing key P1 five times.

IMPORTANT! - After deletion of the "Memory of Closing and Opening limit positions" and "TOTAL Memory", the procedure **9.2 – "Learning the Closing and Opening limit positions"** must be repeated.

WHAT TO DO IF... (troubleshooting guide)

During normal operation, the control unit constantly monitors the automation processes and is designed to indicate any faults that arise, by means of a pre-set sequence of flashes emitted by the courtesy light and red led "L1" on the control unit (the diagnostics flashes always refer to the last action performed by the automation). For an explanation of the number of flashes and associated cause, refer to **Table 6** below:

TABLE 6		
Flashes	Problem	Solution
2 flashes - pause - 2 flashes	During the <i>Closing</i> manoeuvre, the door stops and inverts the current movement.	This reaction is caused by the activation of a specific pair of photocells in the system, on detection of an obstacle. Therefore remove the obstacle on the trajectory of these photocells.
3 flashes - pause - 3 flashes	During the <i>Opening</i> or <i>Closing</i> manoeuvre the door blocks suddenly and the control unit activates a <u>brief</u> inversion of the manoeuvre in progress	The leafs are subject to increased friction due to a sudden obstruction (gust of wind, vehicle, person etc.). If adjustment to sensitivity is required, refer to the Chapter " Adjustments and other optional Functions ".
4 flashes - pause - 4 flashes	During the <i>Opening</i> or <i>Closing</i> manoeuvre the door blocks suddenly and the control unit activates a <i>Stop</i> followed by a brief inversion of movement.	A safety device installed (other than photocells, such as sensitive edges) has detected a sudden obstacle. Therefore remove the obstacle.
5 flashes - pause - 5 flashes	The automation does not respond to commands.	There is a system configuration error. Delete the entire memory of the control unit and repeat installation.
6 flashes - pause - 6 flashes	After a series of manoeuvres sent consecutively, the automation is blocked.	The maximum admissible number of consecutive manoeuvres has been exceeded, causing excessive overheating. Wait for a few minutes to enable the temperature to return below the maximum limit.
7 flashes - pause - 7 flashes	The automation does not respond to commands.	Error in internal electric circuits. Disconnect all power circuits, wait a few seconds and then re-connect. Retry a command; if the automation does not respond this may indicate a serious fault with the electrical board of the control unit or motor wiring. Check and make replacements as necessary.



Tasks reserved for qualified technicians

CAUTION! – All operations in this section must be performed exclusively by skilled and qualified personnel, in observance of the instructions in the manual, and current local legislation and safety standards in the place of installation.

CONNECTING THE AUTOMATION TO THE ELECTRICAL MAINS

CAUTION!– When making this connection, the electrical mains power line must be equipped with short-circuit protection device (between the automation and the mains).

The electrical mains line must also be equipped with a power disconnect device (with overvoltage category III, i.e. minimum gap between contacts of 3 mm) or an equivalent system such as socket with removable plug.

This device, when necessary, guarantees fast and safe disconnection of the power supply and therefore must be placed in a location visible from the automation. If the power disconnect device is not in the vicinity of the automation and not visible from the latter, it must be fitted with a lockout facility to prevent inadvertent or unauthorised connection.

Note – The disconnect devices are not supplied with the product.

AUTOMATION TESTING AND COMMISSIONING

These are the most important phases of automation set-up to ensure maximum system safety. The testing procedure described can also be performed as a periodic check of automation devices.

Testing and commissioning of the automation must be performed by skilled and qualified personnel, who are responsible for the tests required to verify the solutions adopted according to the risks present, and for ensuring observance of all legal provisions, standards and regulations, and in particular all requirements of the standard EN 12445, which establishes the test methods for checking automations for garage doors.

AUTOMATION TESTING

1 Ensure that all specifications in STEP 1 regarding safety have been strictly observed.

2 Using the transmitter, perform door opening and closing tests and ensure that the movement corresponds to specifications.

Test several times to assess smooth operation of the door and check for any defects in assembly or adjustment and any possible points of friction.

3 Check operation of all system safety devices one at a time (photocells, sensitive edges, etc.). Photocells: Activate the device during a *Closing* manoeuvre and check that the control unit stops the manoeuvre and activates a total inversion of the movement (the courtesy light emits 2 flashes, twice). Sensitive edges: Activate the device during an *Opening* or *Closing* manoeuvre and check that the control unit stops the manoeuvre and activates a short inversion of the movement (the courtesy light emits 4 flashes, twice).

4 To check the photocells, and to ensure there is no interference with other devices, pass a cylinder (diameter 5 cm, length 30 cm) through the optic axis joining the pair of photocells (**fig. 45**): pass the cylinder first close to the TX photocell, then close to the RX and lastly at the centre between the two. Ensure that in all cases the device engages, changing from the active status to alarm status and vice versa, and that the envisaged action is generated in the control unit (for example movement inversion in the *Closing* manoeuvre).

5 Measure the force as specified in the standard EN 12445. If the motor force control is used as an auxiliary function for reduction of impact force, test and identify the setting that obtains the best results.

6 Activate a *closing* manoeuvre and check impact force of the door against the floor surface. If necessary, test by discharging pressure to obtain the best results.

AUTOMATION COMMISSIONING

Commissioning can only be performed after positive results of all test phases. Partial or "makeshift" commissioning is strictly prohibited.

1 Prepare the automation technical documentation, which must contain the following documents: Overall layout drawing (see example in **fig. 6, 7, 8**), electrical wiring diagram (see example in **STEP 6**), risk assessment and relative solutions adopted (see forms to be compiled on the website **www.niceforyou.com**), manufacturer's declaration of conformity for all devices

used and the declaration of conformity compiled by the installer (see section TECHNICAL DOCUMENTATION).

- 2 Affix a dataplate on the door, specifying at least the following data: type of automation, name and address of manufacturer (responsible for commissioning), serial number, year of construction and CE mark.
- 3 Prepare and provide the owner with the declaration of conformity; the **“CE Declaration of conformity”** in the section TECHNICAL DOCUMENTATION must be compiled for this purpose.
- 4 Prepare and provide the owner with the form **“Operation manual”** in the section TECHNICAL DOCUMENTATION .
- 5 Prepare and provide the owner with the form **“Maintenance schedule”** in the section TECHNICAL DOCUMENTATION, containing all maintenance instructions for all devices in the automation .
- 6 Before commissioning the automation, ensure that the owner is adequately informed of all associated risks and hazards.
- 7 Permanently affix a label or plate on the door with the image shown in **fig. 46** (minimum height 60 mm) bearing the text **“CAUTION: RISK OF CRUSHING”**.

PERIODIC MAINTENANCE OPERATIONS

In general, this product does not require special maintenance; however, regular checks over time will ensure system efficiency and correct operation of the safety systems installed.

Therefore to ensure correct maintenance, refer to the chapter **“Maintenance Schedule”** in the section “TECHNICAL DOCUMENTATION” at the end of the manual.

PRODUCT DISPOSAL

This product is an integral part of the automation and therefore must be disposed together with the latter.

As in installation, also at the end of product lifetime, the disassembly and scrapping operations must be performed by qualified personnel.

This product comprises various types of materials: some may be recycled others must be disposed of. Seek information on the recycling and disposal systems envisaged by the local regulations in your area for this product category.

Caution! – some parts of the product may contain pollutant or hazardous substances which, if disposed of into the environment, may cause serious damage to the environment or physical health.

As indicated by the symbol alongside, disposal of this product in domestic waste is strictly prohibited. Separate the waste into categories for disposal, according to the methods envisaged by current legislation in your area, or return the product to the retailer when purchasing a new version.

Caution! – Local legislation may envisage serious fines in the event of abusive disposal of this product.

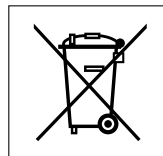

CE DECLARATION OF CONFORMITY

Declaration in accordance with Directives: 1999/5/EC (R&TTE), 2004/108/EC (EMC); 2006/42/EC (MD) annex II, part B

Note - The content of this declaration corresponds to the declaration made in the official document filed in the offices of Nice S.p.a., and particularly the latest version thereof available prior to the printing of this manual. The text contained here has been adapted to meet editorial requirements. A copy of the original declaration may be requested from Nice S.p.a. (TV) I.

Declaration number: 562/SHEL	Revision: 0	Language: EN
Name of manufacturer:	NICE S.p.A.	
Address:	Via Pezza Alta 13, Rustignè Industrial Zone, 31046 Oderzo (TV) Italy	
Person authorized to provide technical documentation:	NICE S.p.A.	
Product type:	Electro-mechanical gearmotor and relative accessories	
Model / Type:	SHEL60, SHEL75	
Accessories:	Radio controls of the series FLO, FLOR, Smilo	

The undersigned Roberto Griffa, as Chief Executive Officer, hereby declares under his own responsibility that the products identified above comply with the provisions of the following directives:

- Directive 1999/5/CE OF THE EUROPEAN PARLIAMENT AND COUNCIL dated March 9 1999 regarding radios and communications terminals and reciprocal recognition of their conformity in accordance with the following harmonized standards:
 - Protection of health (art. 3(1)(a)): EN 62479:2010
 - Electrical safety (art. 3(1)(a)): EN 60950-1:2006 + A11:2009+A12:2011+A1:2010+A2:2013
 - Electromagnetic compatibility (art. 3(1)(b)): EN 301 489-1 V1.9.2:2011, EN 301 489-3 V1.6.1:2013
 - Radio spectrum (art. 3(2)): EN 300 220-2 V2.4.1:2012
- DIRECTIVE 2004/108/EC OF THE EUROPEAN PARLIAMENT AND COUNCIL of December 15 2004 concerning alignment of Member States' legislation regarding electromagnetic compatibility and abrogating directive 89/336/EEC, according to the following harmonized standards:
 - EN 61000-6-2:2005, EN 61000-6-3:2007+A1:2011

The product also complies with the following directive in accordance with the requirements for “quasi-machines”:

- Directive 2006/42/EC OF THE EUROPEAN PARLIAMENT AND COUNCIL of May 17 2006 regarding machines and amending directive 95/16/EC (consolidated text)
 - I declare that the pertinent technical documentation has been prepared in accordance with Annex VII B to Directive 2006/42/EC and that the following essential requirements have been met: 1.1- 1.1.2- 1.1.3- 1.2.1-1.2.6- 1.5.1-1.5.2- 1.5.5- 1.5.6- 1.5.7- 1.5.8- 1.5.10- 1.5.11
 - The manufacturer agrees to send the national authorities pertinent information on the “quasi-machine” in response to a motivated request without affecting its intellectual property rights.
 - If the “quasi-machine” is operated in a European country with an official language other than the language used in this declaration, the importer must associate a translation with this declaration.
 - The “quasi-machine” must not be operated until the final machine in which it is to be incorporated is declared to conform to the provisions of Directive 2006/42/EC, if applicable to it.

The product also complies with the following standards: EN 60335-1:2002 + A1:2004 + A11:2004 + A12:2006 + A2:2006 + A13:2008 + A14:2010 + A15:2011, EN 60335-2-103:2003+A11:2009

The parts of the product which are subject to the following standards comply with them: EN 13241-1:2003+A1:2011, EN 12445:2002, EN 12453:2002, EN 12978:2003+A1:2009

Oderzo, 16 March 2016

Ing. **Roberto Griffa** (Chief Executive Officer)

TECHNICAL SPECIFICATIONS OF PRODUCT COMPONENTS

WARNINGS:

- The product SHEL60KIT - SHEL75KIT is produced by Nice S.p.a. (TV) I.
- All technical specifications stated in this section refer to an ambient temperature of 20°C (± 5°C).
- Nice S.p.a. reserves the right to apply modifications to the product at any time when deemed necessary, while maintaining the same functionalities and intended use.

GEARMOTORS:	SHEL60KIT	SHEL75KIT
Technology adopted	24 V motor	
Power supply	230 Vac 50/60 Hz	
Maximum start-up torque	9 Nm	12 Nm
Nominal torque	6 Nm	7,5 Nm
Maximum thrust	600 N	750 N
Nominal thrust	350 N	450 N
Maximum power	200 W	280 W
Movement speed	0.07 ÷ 0.13 m/s	0.08 ÷ 0.14 m/s
Maximum continuous operation time	4 minutes	
No. Cycles per hour at nominal torque (20°)	8	
Ambient operating temperature	-20° C ÷ +50° C	
Dimensions	305 x 109 h x 130 (mm)	
Weight	4 kg	
Insulation class	1	
Courtesy light	12 V / 10 W fitting BA15	
STOP Input	For normally open, normally closed or constant resistance 8,2 KΩ contacts; in self-learning (a variation with respect to the memorised status causes the command "STOP").	
STEP-STEP Input	For normally open contacts	
PHOTO input	For safety devices with normally closed contacts	
Radio receiver	Built-in	
Programmable functions	4 programmable functions (see paragraph 6.3) Self learning of type of STOP device (NO contact, NC contact or 8,2 KΩ resistance)	
Functions in self-learning mode and partial open points	Self-learning of door opening and closing positions and calculation of deceleration	
Use in particularly acid or saline potentially explosive atmospheres	No	
Protection class	IP 40 use indoors or in protected environments	
Estimated durability (*)	From 40.000 to 80.000 manoeuvre cycles	

(*) **Note** – The estimated product durability ranges from 40.000 to 80.000 manoeuvre cycles. To calculate the probable durability of your automation proceed as follows:

a) – evaluate the conditions of use and force levels involved on your system, for example:

- the weight and length of the garage door;
- perfect balancing of the garage door;
- maintenance conditions of the garage door hinges;
- type of leaf; Solid or with many openings;
- the presence of strong winds;
- frequency of automation use.

b) – from these values, obtain a value expressed as a percentage which, in general, defines the greatest or smallest degree of automation wear.

c) – on the graph alongside, locate the estimated percentage (at point "b") and read the corresponding number of manoeuvre cycles.

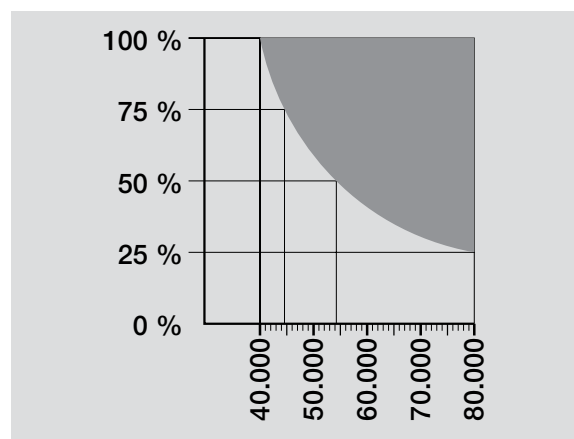

TRANSMITTER FLO4R-S

DESCRIPTION	DATA
Type	4-channel transmitter for radio control
Frequency	433.92 MHz
Encoding	Rolling code with 52 Bit code type FLOR
Keys	4
Radiated power	100 μW
Power supply	12 Vdc with battery type 23 A
Battery lifetime	1 year, estimated on the basis of 20 commands/day of the duration of 1s at 20°C (battery efficiency is reduced at low temperatures)
Ambient operating temperature	-40°C ÷ 85°C
Protection class	IP 40 (use in the home or protected environments)
Dimensions	72 x 40 h x 18 mm
Weight	30 g

• **Before using your automation system for the first time**, ask the installer to explain the origin of any residual risks; take a few minutes and read the users **instructions manual given you by the installer**. Retain the manual for future use and deliver it to any subsequent owner of the automation system.

• **Your automation system is a machine that will faithfully execute your commands**; unreasonable or improper use may generate dangers: do not operate the system if there are people, animals or objects within its range of operation.

• **Children**: automation systems are designed to guarantee high levels of safety and security. They are equipped with detection devices that prevent movement if people or objects are in the way, guaranteeing safe and reliable activation. However, children should not be allowed to play in the vicinity of automated systems; to prevent any accidental activations, keep all remote controls away from children: **they are not toys!**

• **Malfunctions**: If you notice that your automation is not functioning properly, disconnect the power supply to the system and operate the manual release device. Do not attempt to make any repairs; call the installation technician and, in the meantime, operate the system like a non-automatic door after releasing the gearmotor as described below.

• **Maintenance**: Like any machine, your automation needs regular periodic maintenance to ensure its long life and total safety. Arrange a periodic maintenance schedule with your installation technician. Nice recommends that maintenance checks be carried out every six months for normal domestic use, but this interval may vary depending on the intensity of use. Only qualified personnel are authorized to carry out checks, maintenance operations and repairs.

• Do not modify the system or its programming and adjustment parameters in any way, even if you feel capable of doing it: your installation technician is responsible for the system.

• The final test, the periodic maintenance operations and any repairs must be documented by the person who has performed them; these documents must remain under the custody of the owner of the system.

The only recommended maintenance operations that the user can perform periodically concern the cleaning of the photocell glasses and the removal of leaves and debris that may impede the automation. To prevent anyone from activating the door **release the automation system** (as described below). Use a slightly damp cloth to.

• **Disposal**: At the end of its useful life, the automation must be dismantled by qualified personnel, and the materials must be recycled or disposed of in compliance with the legislation locally in force.

• **In the event of malfunctions or power failures**. While you are waiting for the technician to come (or for the power to be restored if your system is not equipped with buffer batteries), you can operate the system like any non-automatic door. In order to do this you need to manually release the gearmotor (this operation is the only one that the user of the automation is authorized to perform): This operation has been carefully designed by Nice to make it extremely easy, without any need for tools or physical exertion.

Manual movement and release: before carrying out this operation please note that release can only occur when the door is stopped.

1. Pull the release cord down until you hear the release of the carriage (**fig. A**).
2. The door can now be moved manually (**fig. B**).
3. To restore automation operation return the door to the initial position until you hear the carriage engage.

Control with safety devices out of order: If the safety devices are malfunctioning, it is still possible to control the door.

- Operate the door control device (remote control or key-operated selector switch etc.). If the safety devices enable the operation, the door will open and close normally, otherwise the flashing light flashes a few times but the manoeuvre does not start (the number of flashes depends on the reason why the manoeuvre is not enabled).

- In this case, **actuate** the control again within 3 seconds and **keep it actuated**. - After approximately 2 s the door will start moving in the "man present" mode, i.e. so long as the control is maintained the door will keep moving; as soon as the control is released the door will stop.

If the safety devices are out of order the automation must be repaired as soon as possible.

Replacing the Remote Control Battery: if your radio control, after a period of time, seems not to work as well, or not to work at all, it may simply be that the battery is exhausted (depending on the type of use, it may last from several months up to one year and more). In this case you will see that the light confirming the transmission is weak, or does not come on, or comes on only briefly. Before calling the installation technician try exchanging the battery with one from another operating transmitter: if the problem is caused by a low battery, just replace it with another of the same type.

WARNING! – The batteries contain polluting substances: do not dispose of them together with other waste but use the methods established by local regulations.

Lamp replacement: before proceeding, disconnect SHEL60KIT - SHEL75KIT from the power supply.

1. To open the white cover, unscrew the lateral screw and slide off the cover.
2. Remove the bulb by pressing it upwards and then rotating. Insert a new bulb (12V / 21W fitting BA15).

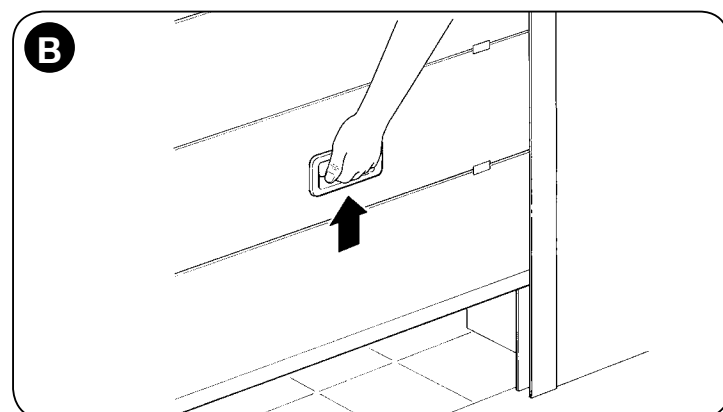
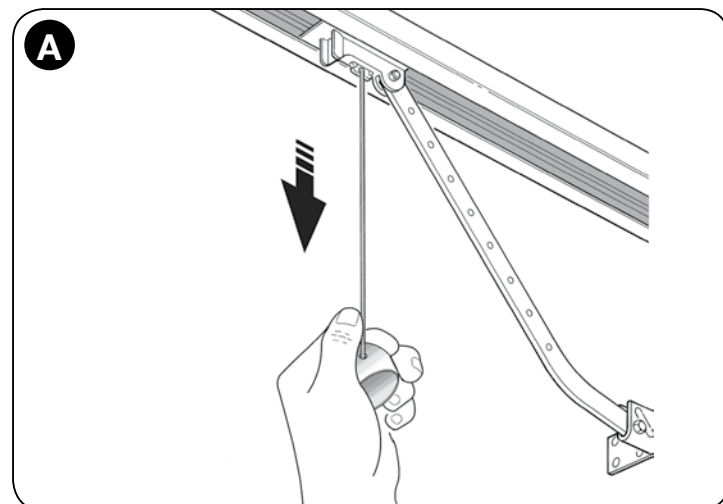

1 EN SECTIONAL - IT SEZIONALE
 - FR SECTIONNELLE - ES SECCIONAL - DE SEKTIONALTOR - PL BRAMA SEGMENTOWA - NL SECTIONAAL

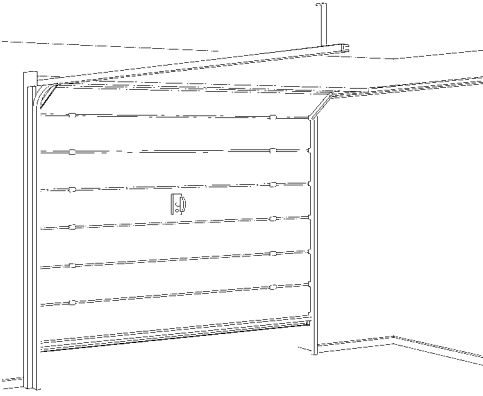

EN PROJECTING - IT DEBORDANTE - FR DÉBORDANTE - ES DESBORDANTE - DE AUSFAHREND - PL WYSTAJĄCA - NL BUITEN DE GEVEL DRAAIEND

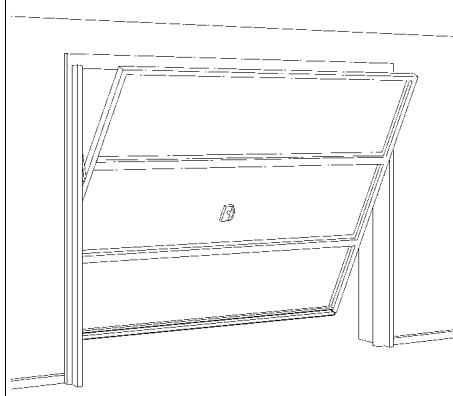

EN NON-PROJECTING - IT NON DEBORDANTE - FR NON DÉBORDANTE - ES NO DESBORDANTE - DE NICHT AUSFAHREND - PL NIWYSTAJĄCA - NL BINNEN DE GEVEL BLIJVEND

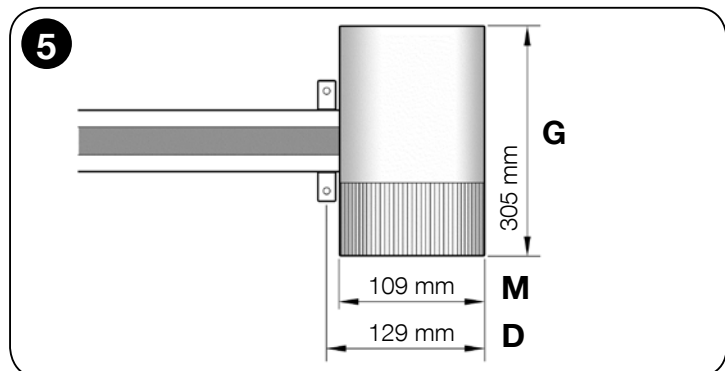
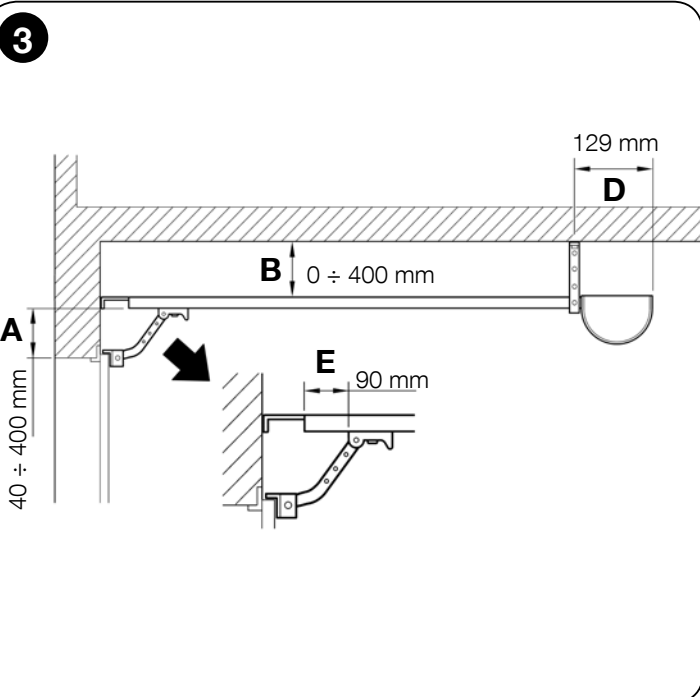
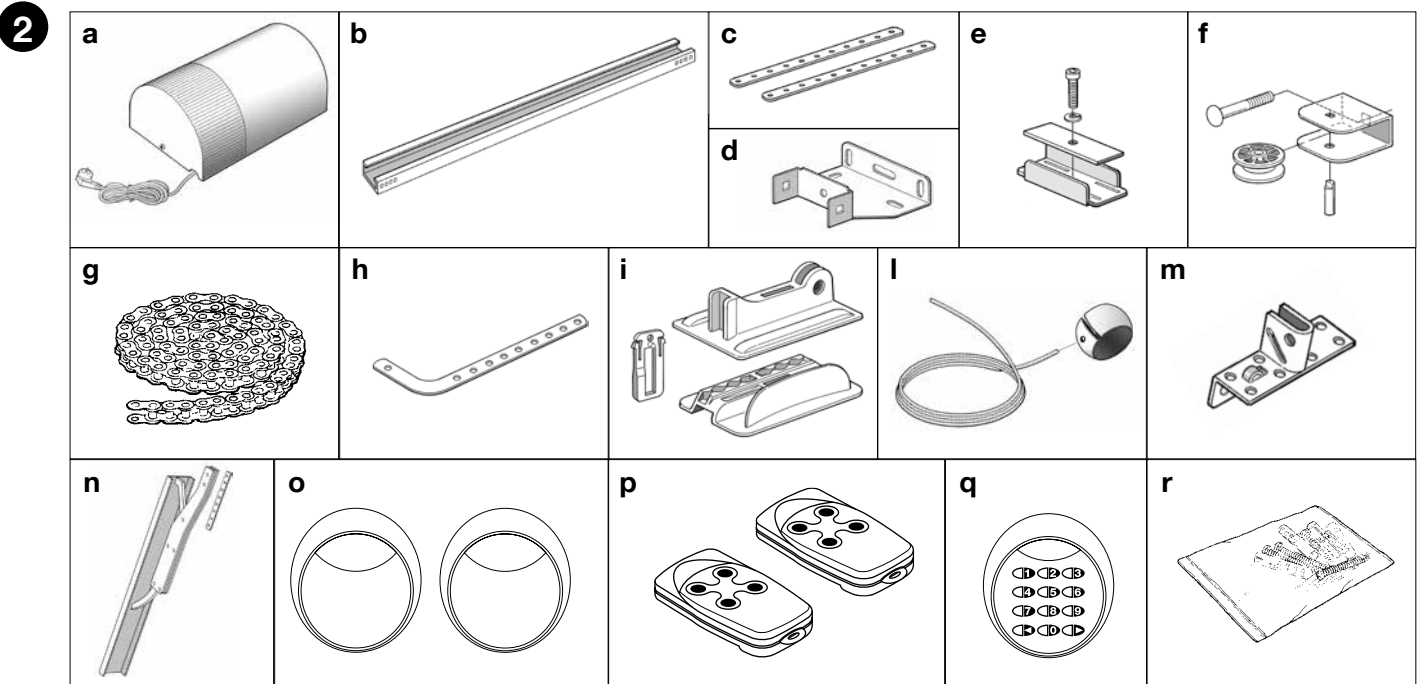
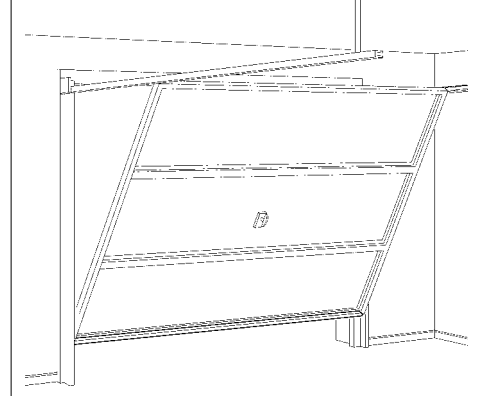

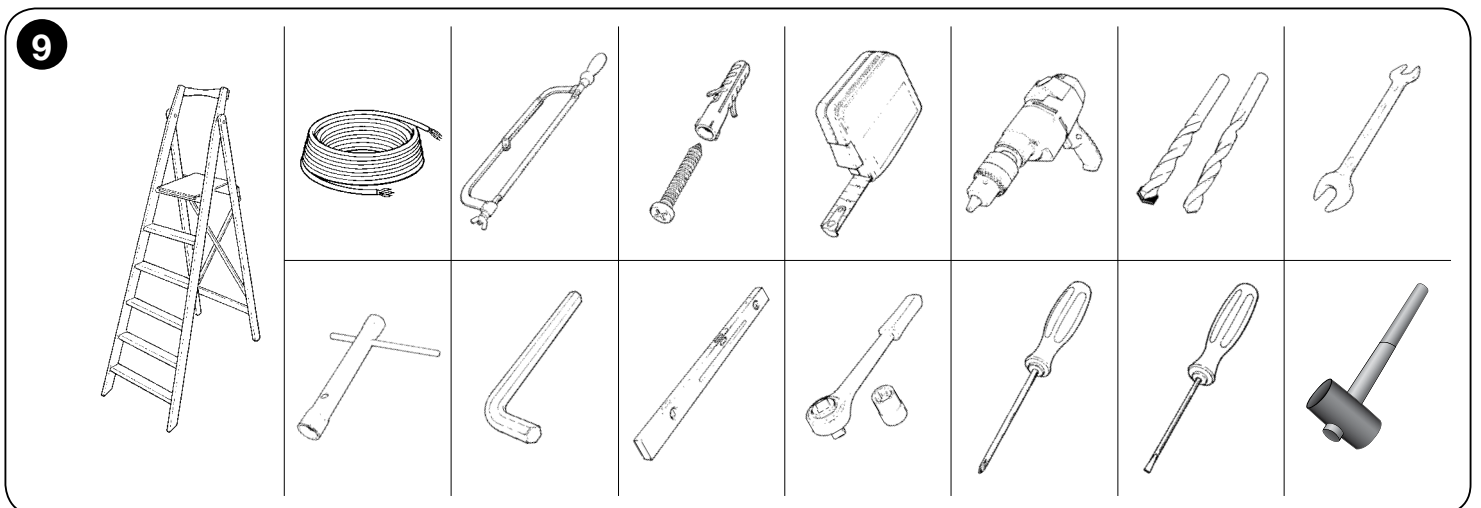
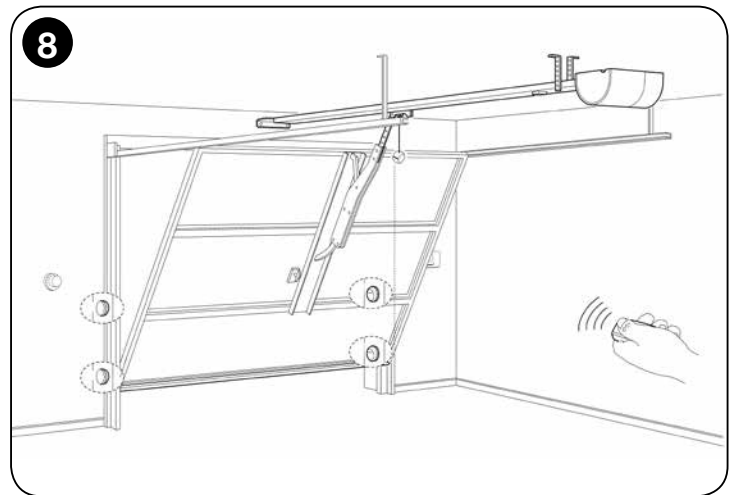
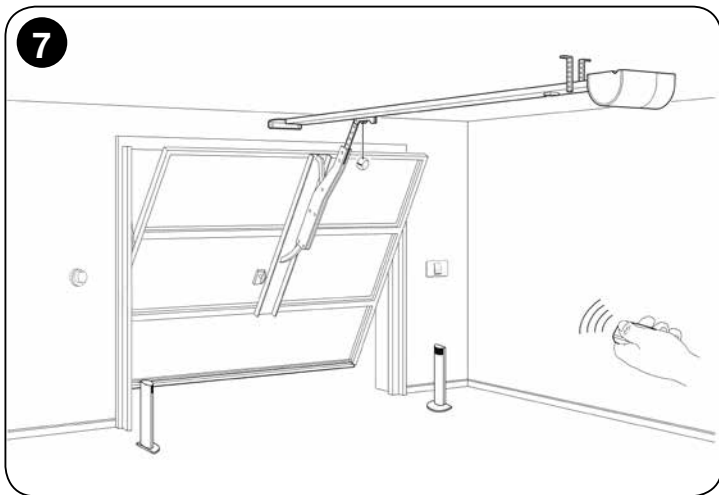
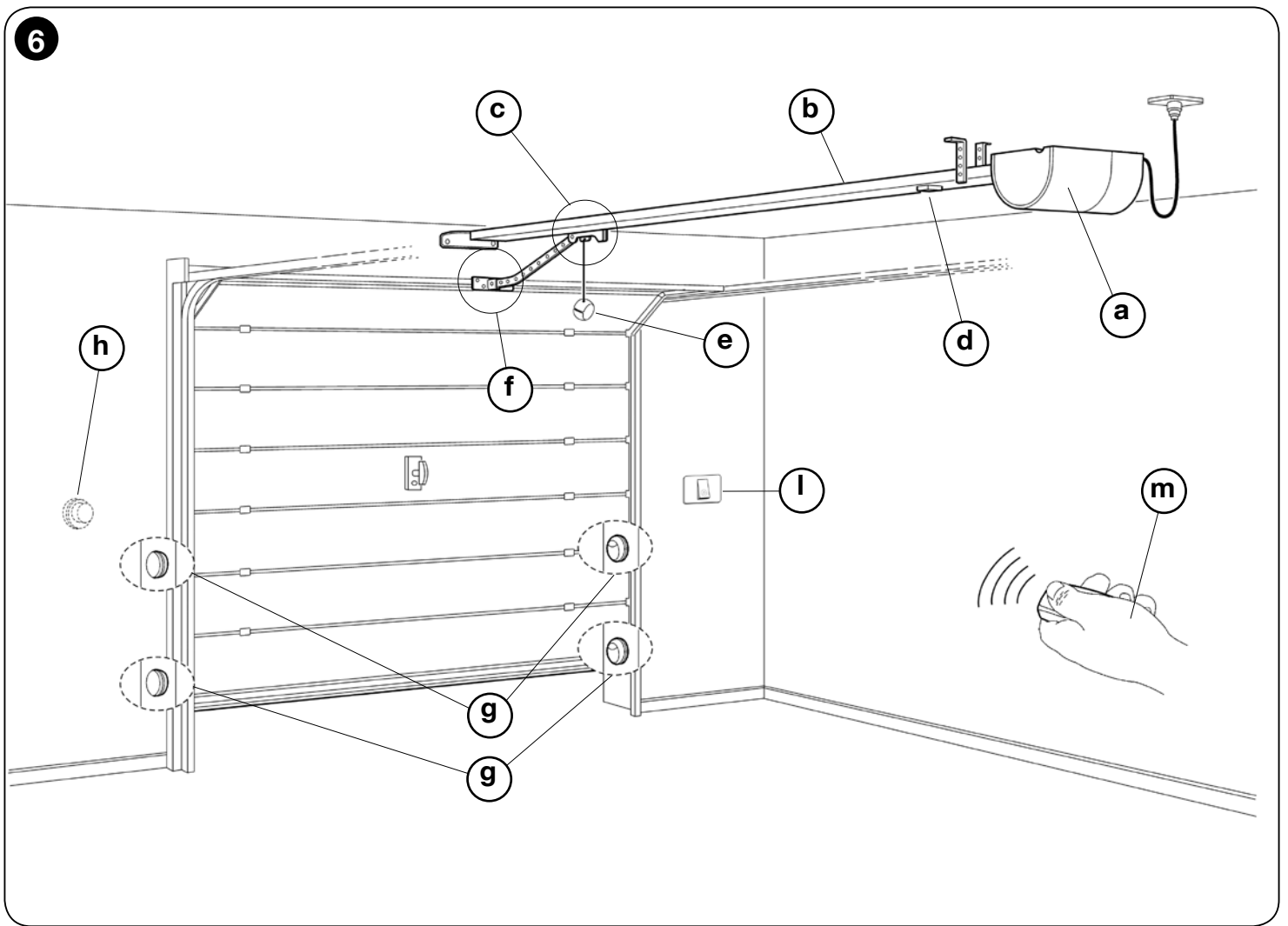

10

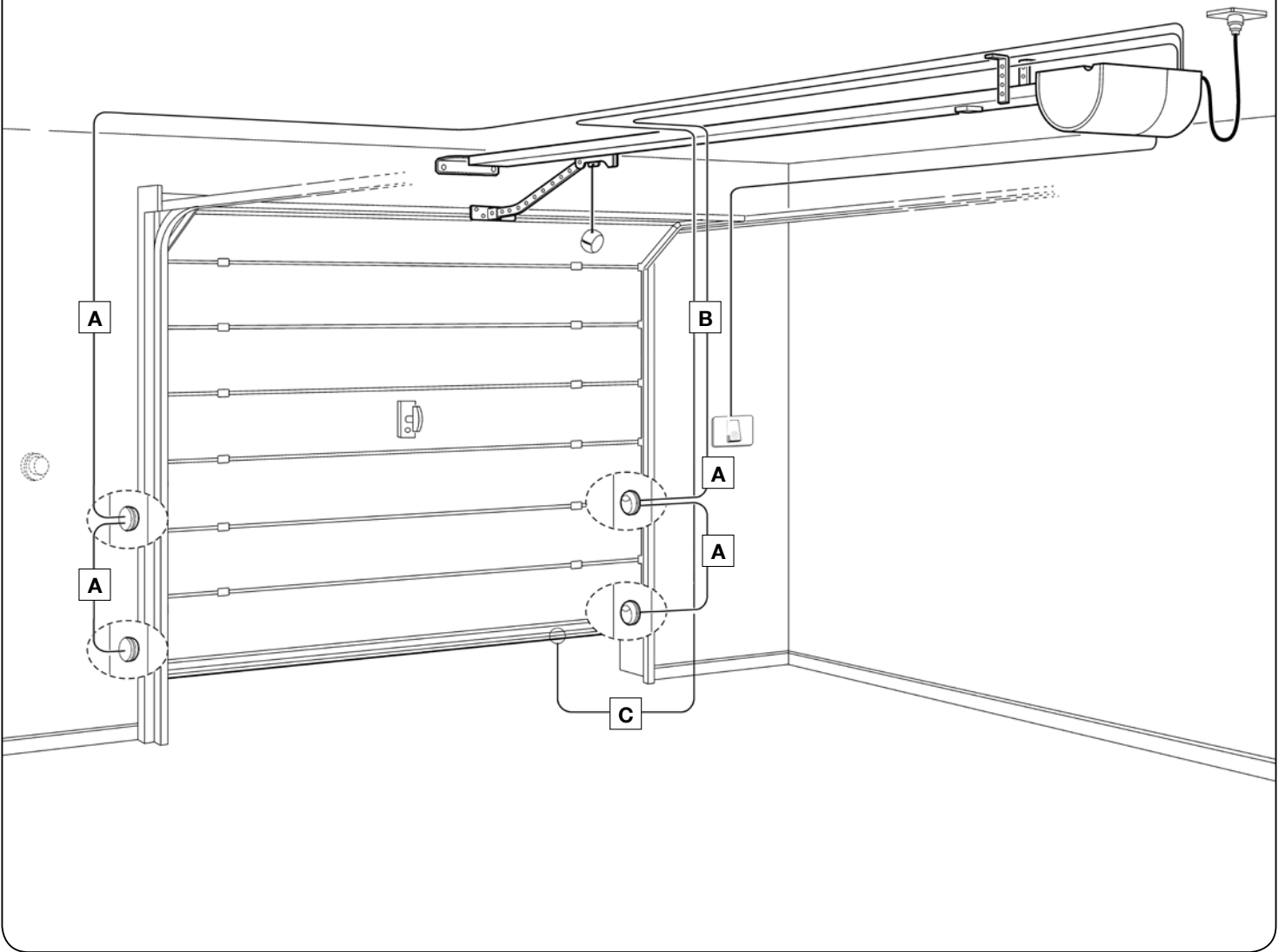

11

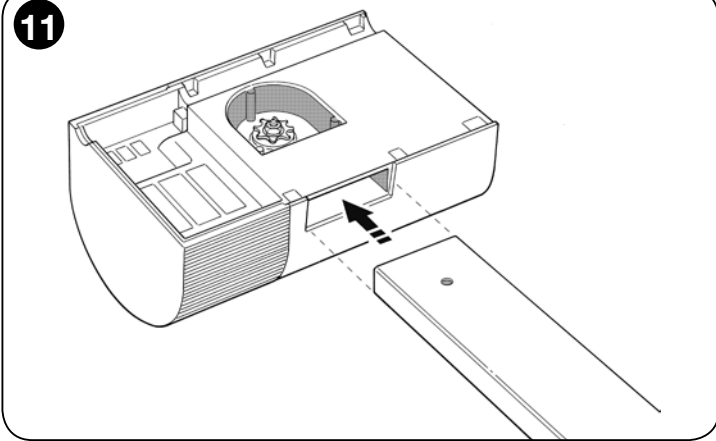

12

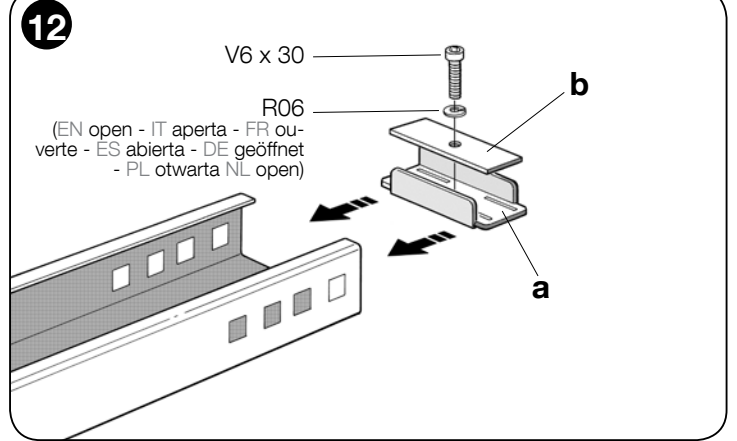

13

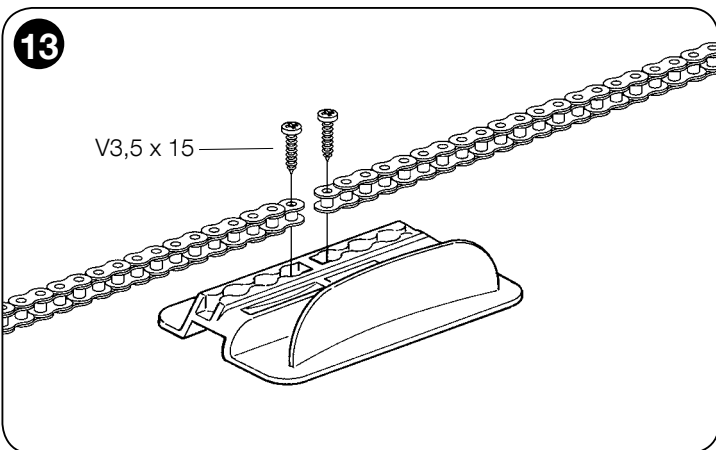

14

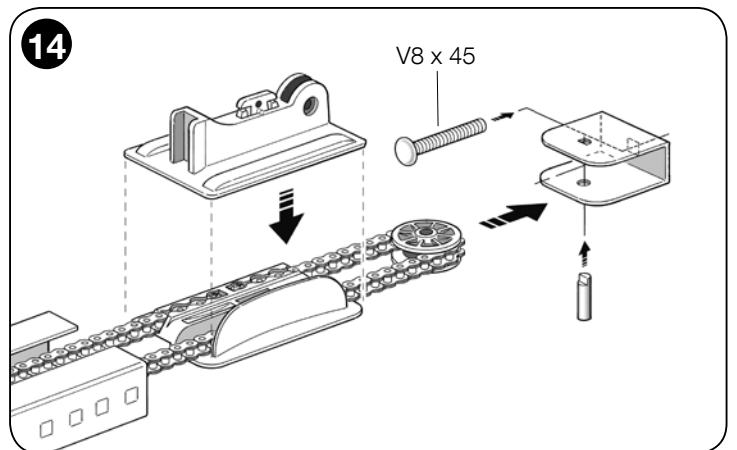

15-a

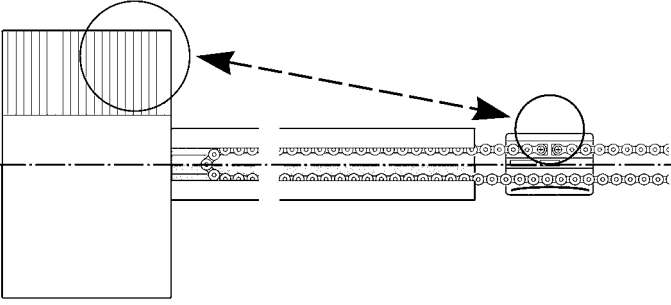

15-b

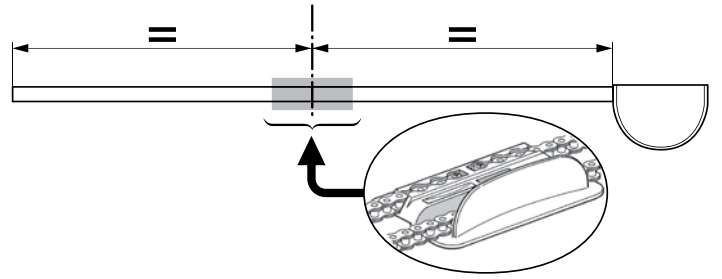

16

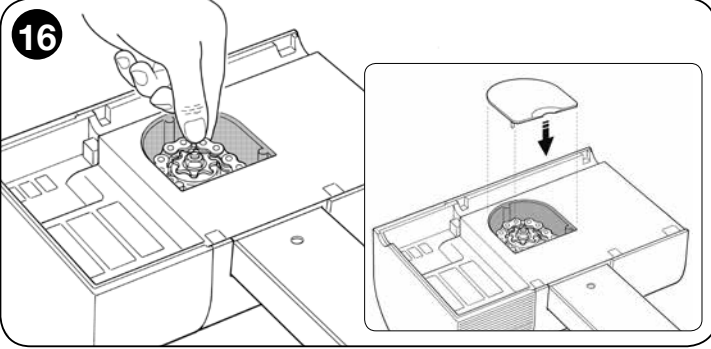

17

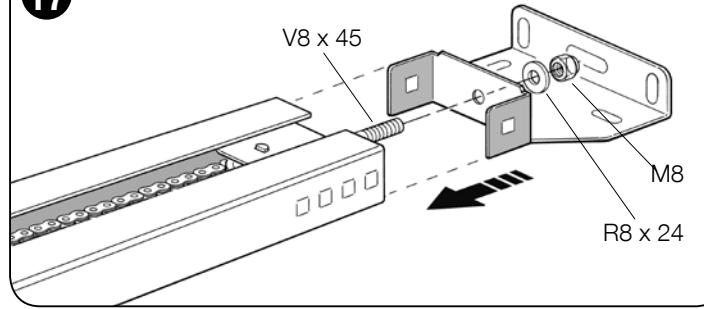

18

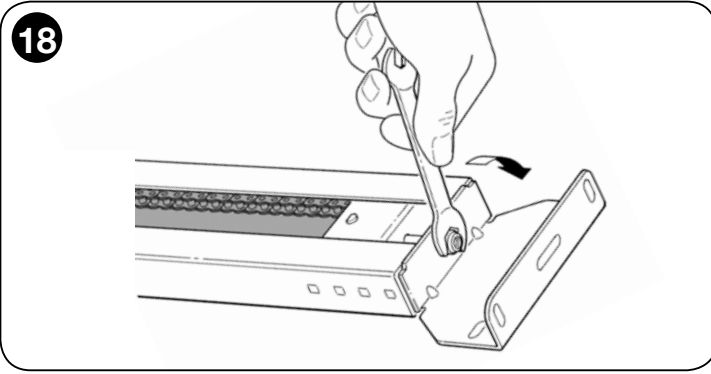

19

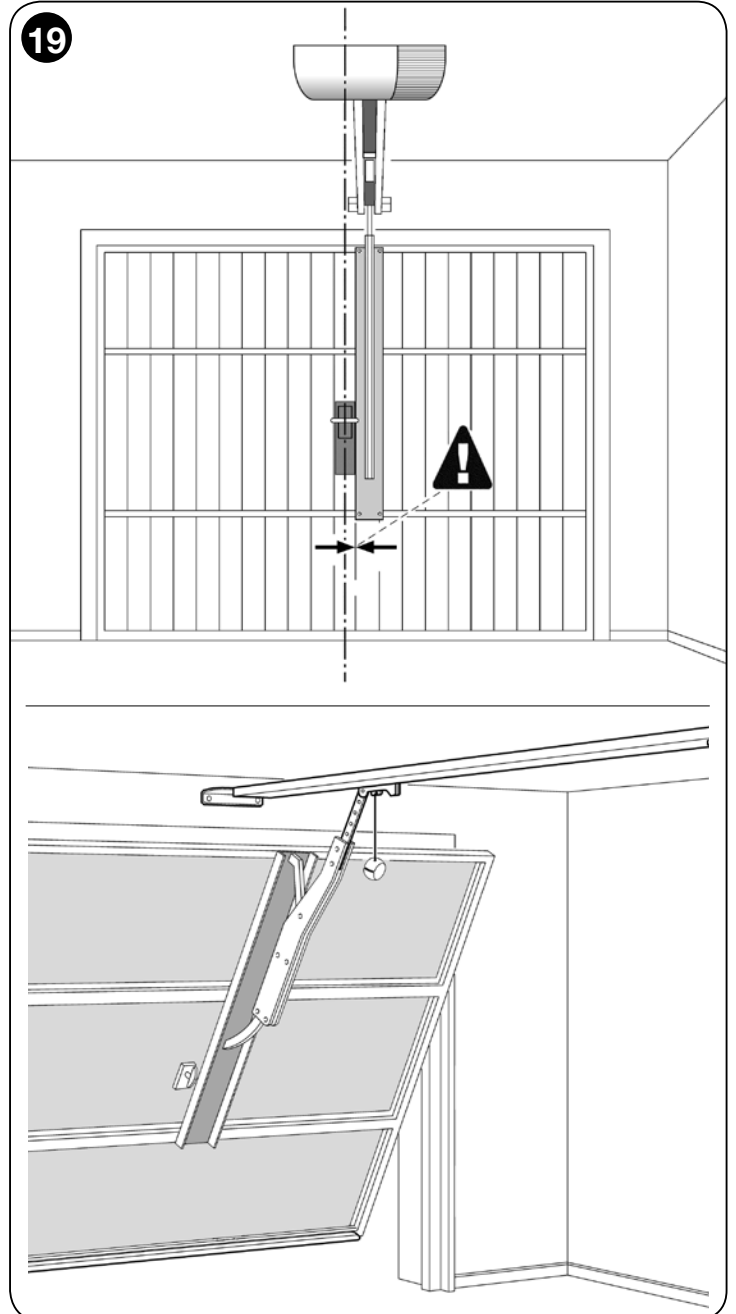

20

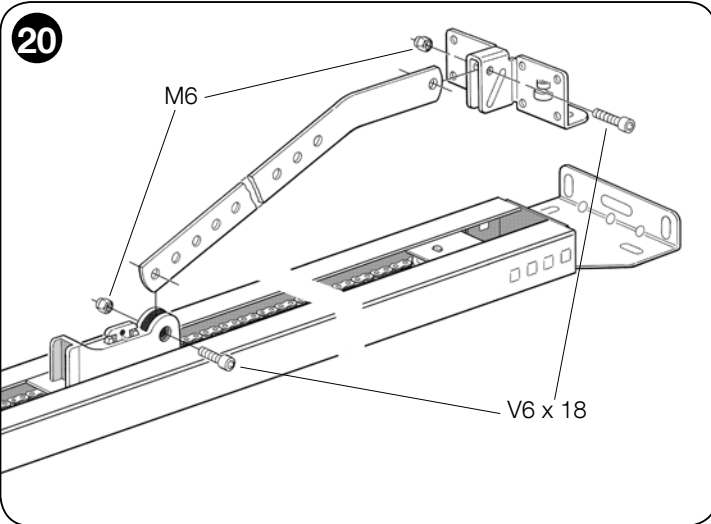

21

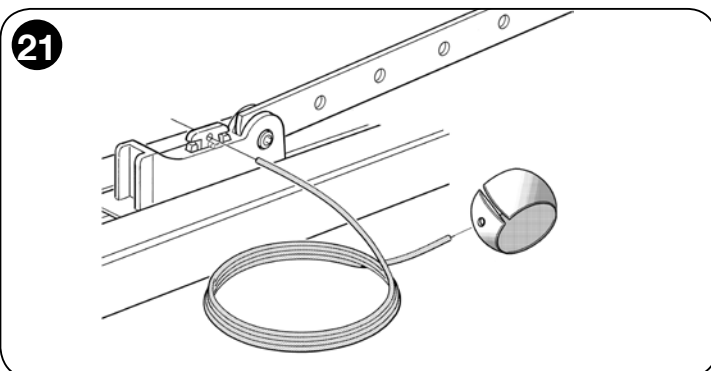

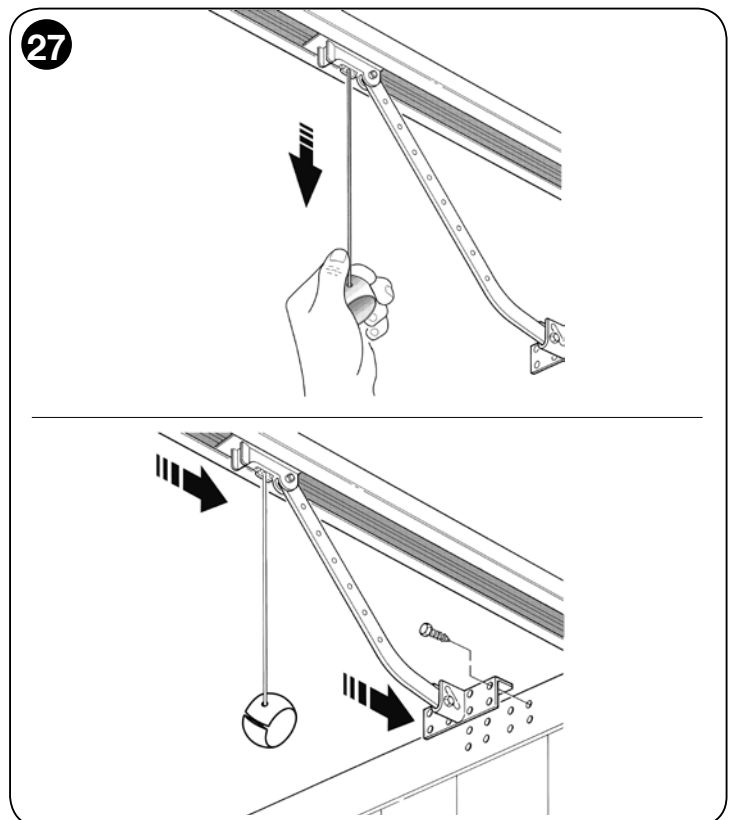
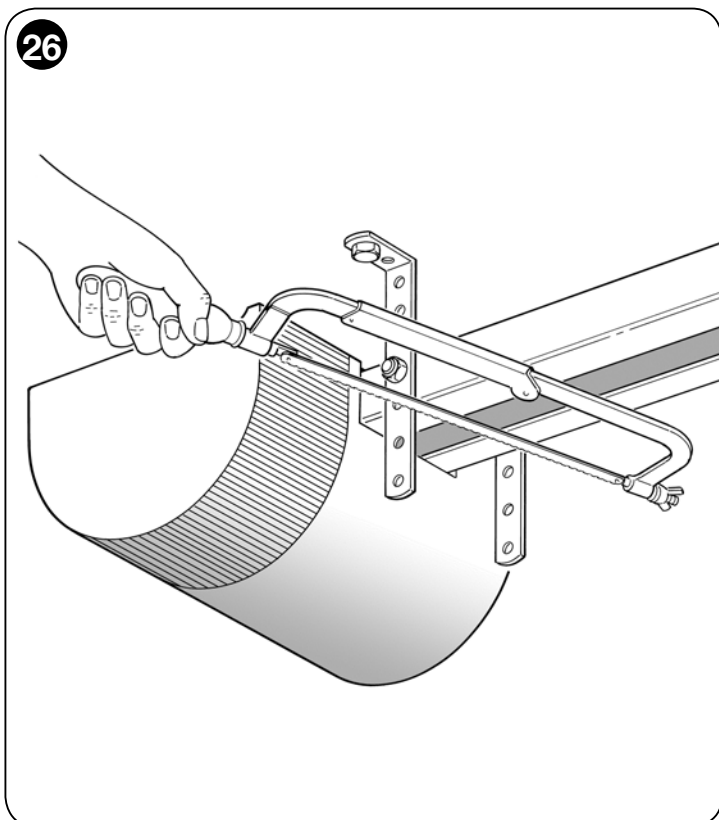
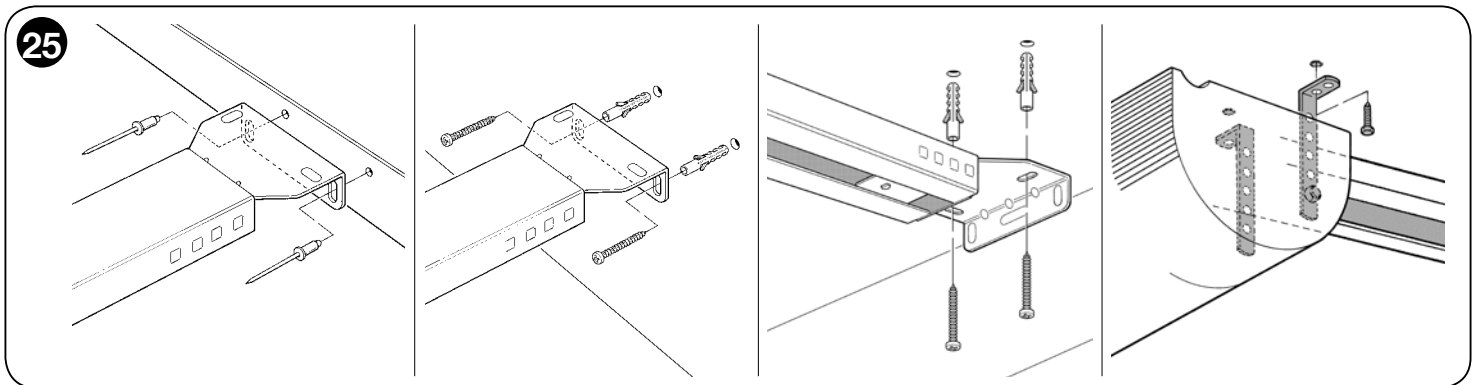
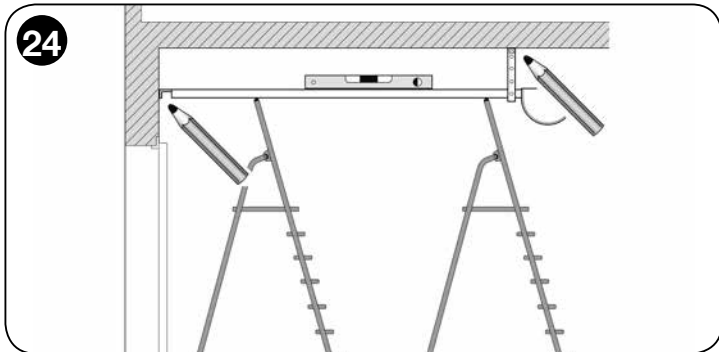
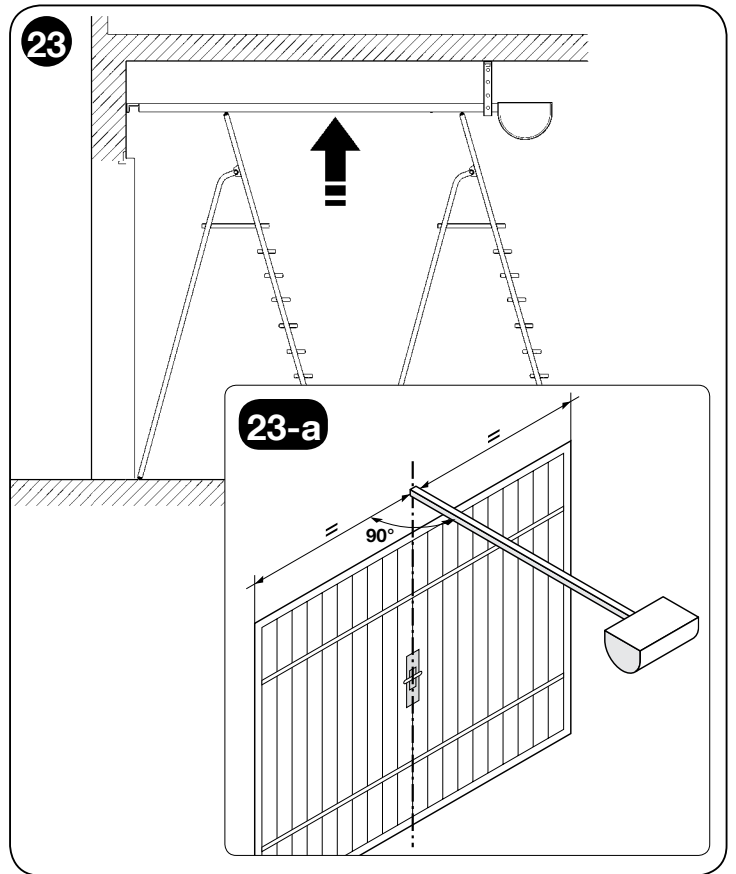
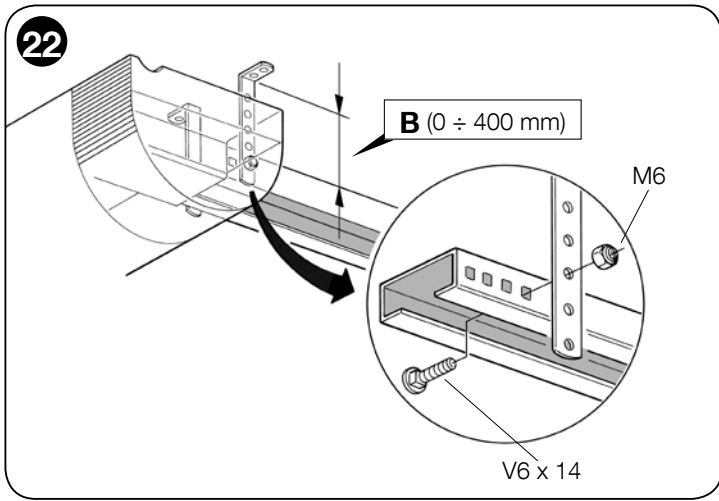

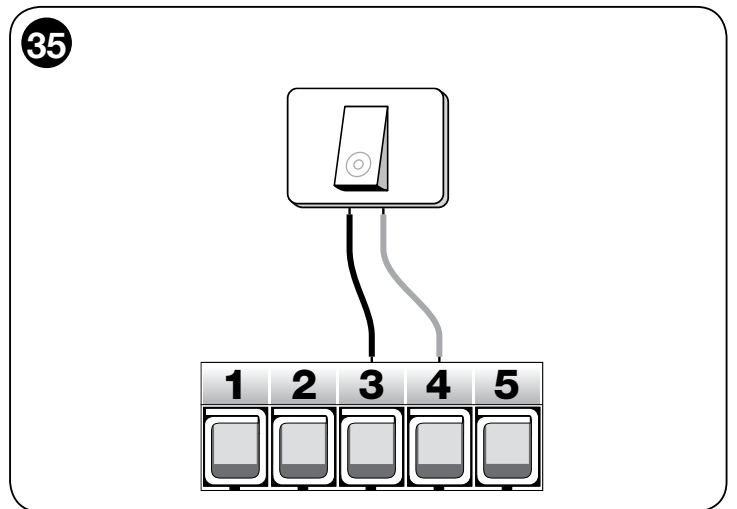
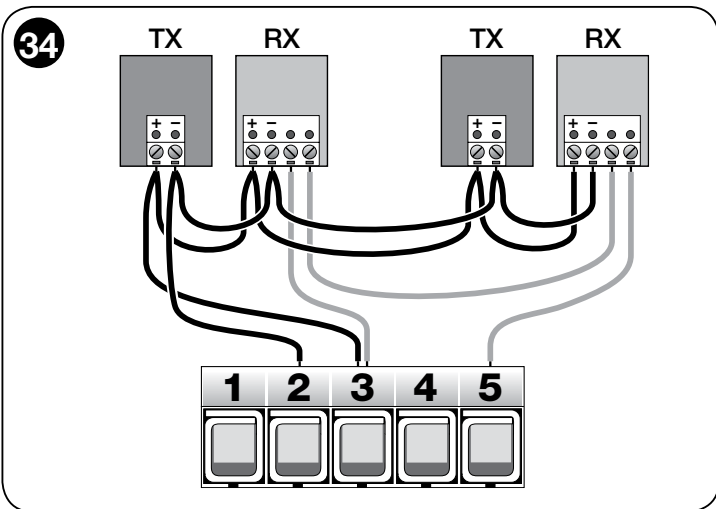
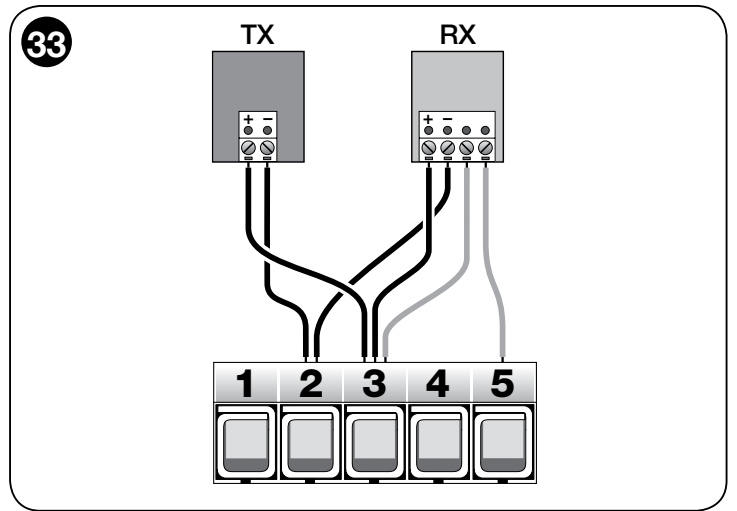
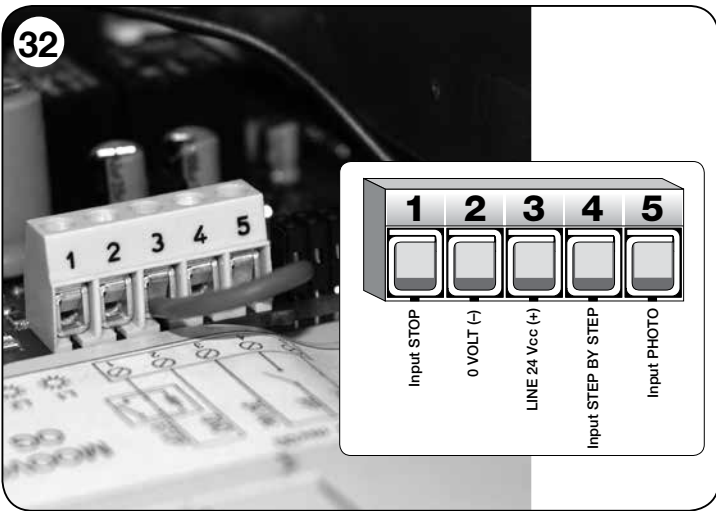
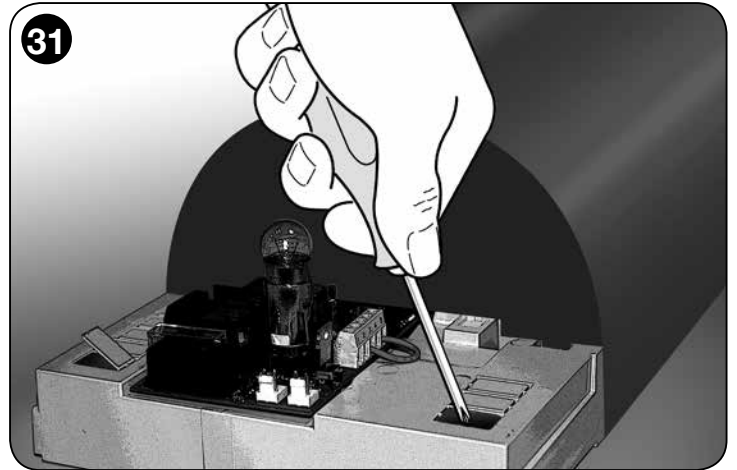
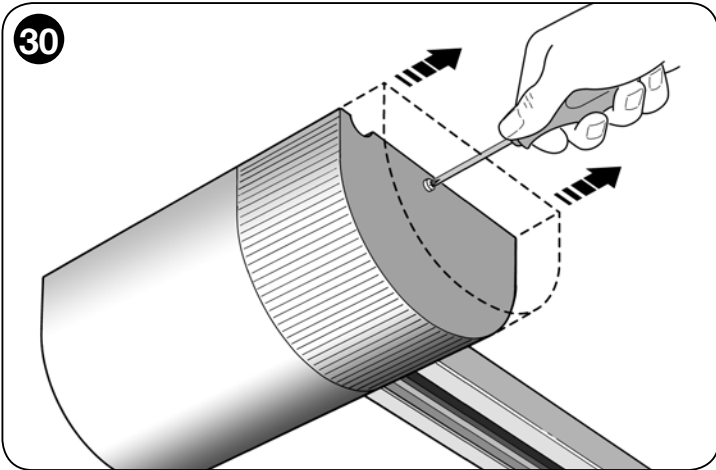
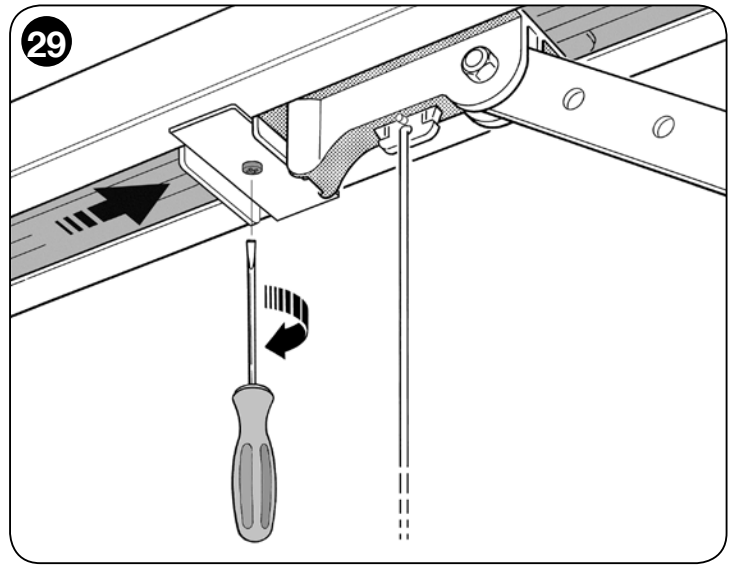
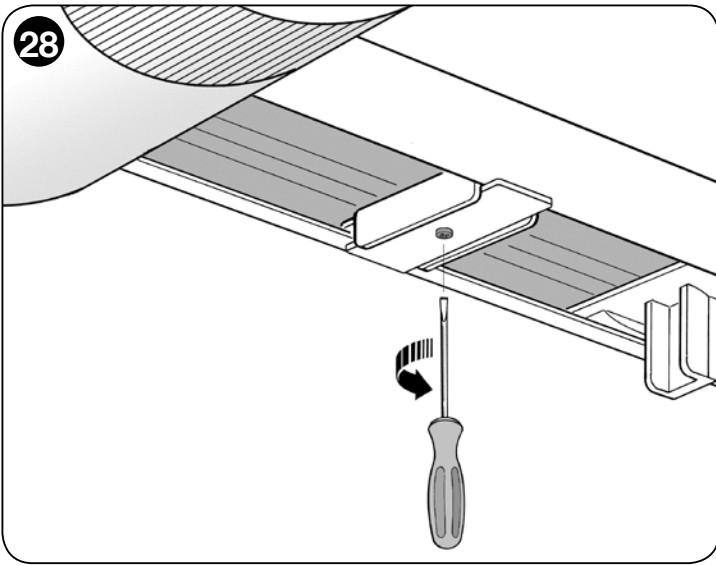

36

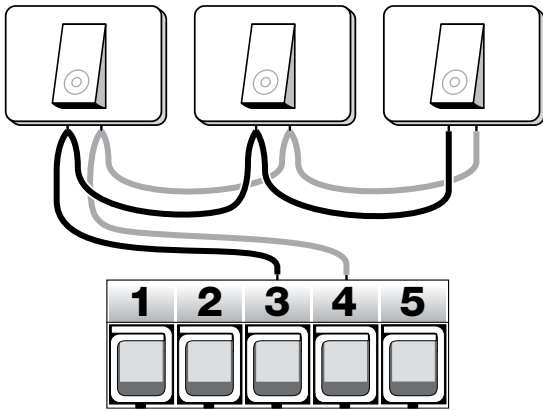

37

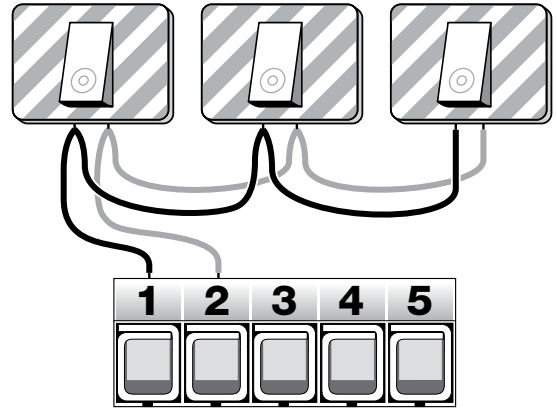

38

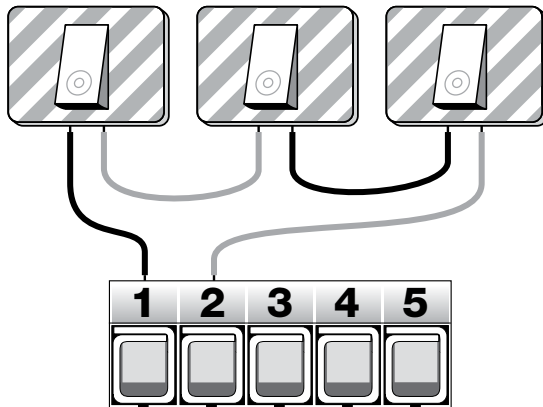

39

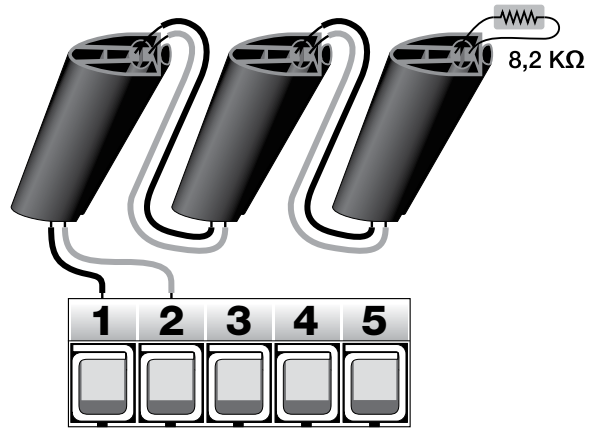

40

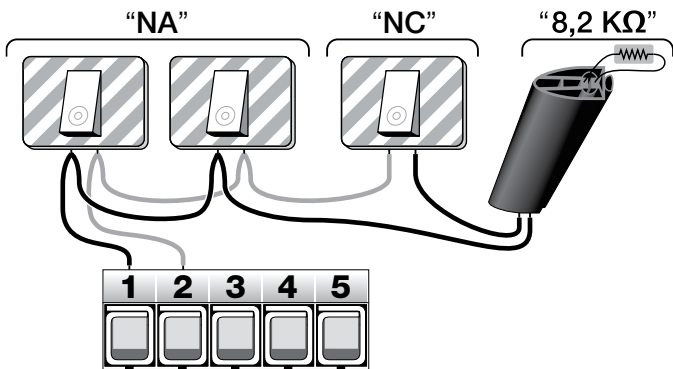

41

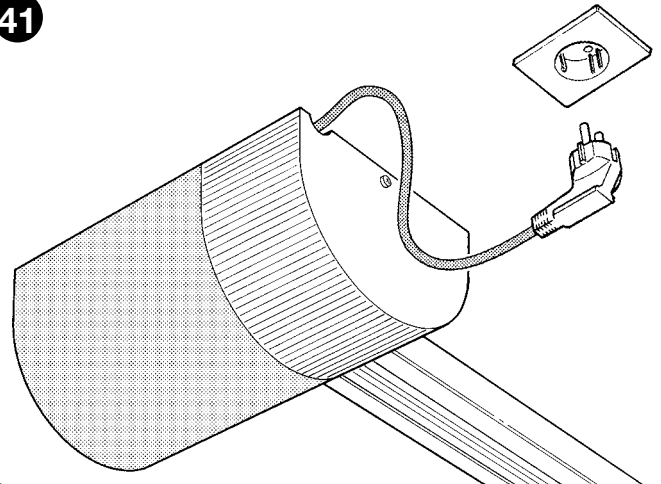

42

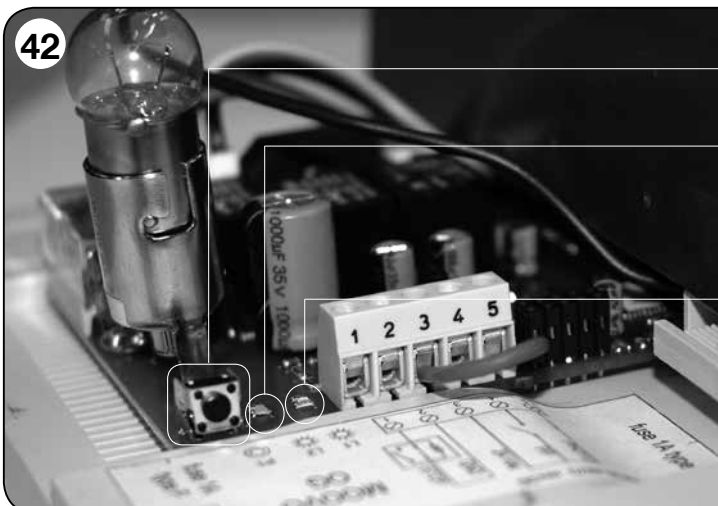

- P1
- EN Green Led - IT Led verde
FR Led verte - ES Led verde - DE grüne Led
PL Zielona dioda - NL Groene led
- EN Red Led - IT Led rosso
FR Led rouge - ES Led rojo
DE rote Led - PL Czerwona dioda
NL Rode led

43

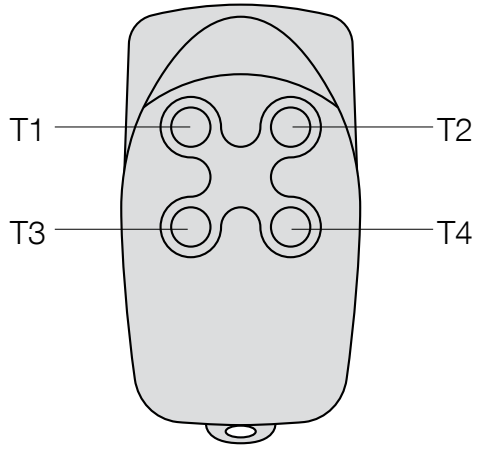

44

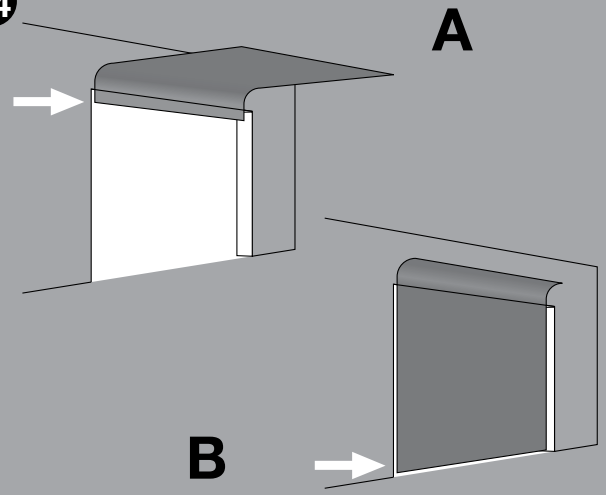

45

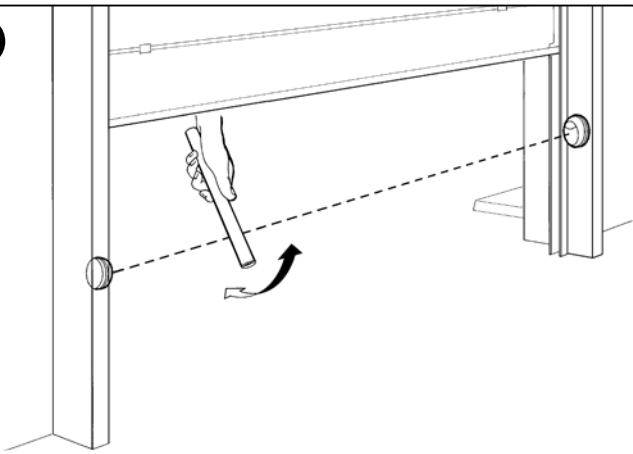

46

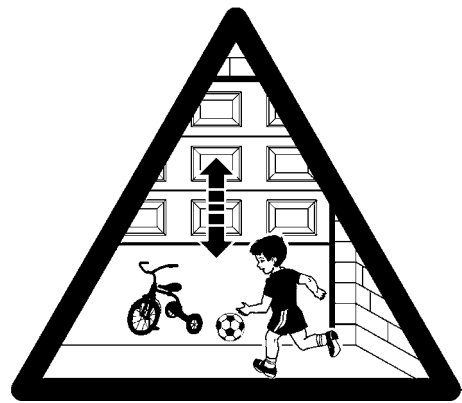



Nice SpA
Oderzo TV Italia
info@niceforyou.com

www.niceforyou.com